

# Emerson TopWorx™ PD200 Smart Valve Positioner



# Safe Use - User Instructions

## **WARNING**

### To reduce risk of death, serious injury or property damage:

- Personnel installing, maintaining, or operating this equipment must be qualified, must read, understand, and follow these instructions before proceeding.
- This document must be retained for future reference.
- Please contact local Topworx representative for questions, clarifications, or comments.

## **NOTICE**

### Instructions for safe selection, installation, use, maintenance, and repair

- Do not use the positioner outside the operating range, as doing so may cause failures or even accidents with serious injuries. See Section 2 - Specifications.
- For installation in a potentially explosive atmosphere, make sure you have the positioner correctly specified for this purpose. Products for explosion hazard areas have the -EN suffix at the end of the code.
- Installation of the Intrinsically Safe positioner must follow the recommendations of IEC 60079-14.
- Never touch the moving parts of the positioner when it is in operation, as the movement of the valve may cause accidents with serious injuries
- The positioner must be installed by qualified technical personnel. We warn of the risk of damage to persons and goods resulting from improper installation or configuration.

### Warning Symbols Used in this Manual

This manual contains notes that must be observed for your personal safety as well as to prevent material damage.

The following symbols and explanations are listed according to their degree of danger:

## **DANGER**

### **DANGER - Serious damage to health / danger of death**

This symbol in combination with the signal word "DANGER" indicates an immediate danger. Failure to observe the safety warning causes death or very serious injury.

## **ATTENTION**

### **ATTENTION - Personal Injury**

This symbol in combination with the signal word "WARNING" indicates a possibly dangerous situation. Failure to observe the safety warning can cause death or very serious injury.

## **CAUTION**

### **CAUTION - Risk of injury**

This symbol in combination with the signal word "CAUTION" indicates a possibly dangerous situation. Failure to observe the safety warning can cause injury.

## **WARNING**

### **WARNING - Material Damage**

This symbol in combination with the signal word "WARNING" indicates a possibly harmful situation. Failure to observe the safety warning may permanently damage the product or lead to control.

### **IMPORTANT**

This symbol in combination with the signal word "IMPORTANT" indicates tips for the user or especially useful information about the product or its use. It does not signal a dangerous or harmful situation.

# Table of Contents

<b>Section 1: Introduction.....</b>	<b>1</b>
1.1 General Notes.....	1
1.2 Proper Use .....	1
1.3 Qualified Technical Staff .....	2
1.4 Exclusion of Liability .....	2
<b>Section 2: Specifications.....</b>	<b>3</b>
<b>Section 3: Overview .....</b>	<b>5</b>
3.1 Enclosure.....	6
3.2 Identification Label Information.....	6
3.3 Manipulated Variable .....	8
3.4 Scope of Supply.....	9
<b>Section 4: Principle of Operation .....</b>	<b>9</b>
<b>Section 5: Mechanical Installation.....</b>	<b>11</b>
5.1 What are Rotary Pneumatic Actuators?.....	11
5.2 What are Pneumatic Linear Actuators? .....	11
5.3 Rotary Actuator Installation.....	12
5.3.1 Mounting the Rotary NAMUR Bracket to the Actuator.....	13
5.4 Linear Actuator Installation .....	16
5.4.1 Mounting the Guide Lever .....	17
5.4.2 Installation of the Feedback Lever and Support .....	17
5.4.3 Yoke Castle Mount.....	18
5.4.4 Mounting on a Pillar Type Castle.....	18
5.4.5 Feedback Lever Types.....	19
5.4.6 Standard Installation .....	19
<b>Section 6: Pneumatic Connections .....</b>	<b>25</b>
6.1 Manifold Types .....	26
6.2 Pneumatic Connection on Rotary Actuator .....	27
6.3 Pneumatic Connection on Linear Actuator.....	28
<b>Section 7: Electrical Connections .....</b>	<b>29</b>
7.1 Cable Entry.....	29
7.2 Grounding.....	30
7.3 Electrical Connection .....	30

7.4 Alarm Limit Switch Connection .....	33
7.4. Micro Switches.....	33
<b>Section 8: Configuration .....</b>	<b>40</b>
8.1 Configuration Buttons.....	40
8.1.1 Magnetic Key.....	41
8.2 Entering and Navigating the Configuration Menu .....	42
8.3 Fast Calibration .....	44
8.4 Fast PID .....	45
8.5 Configuration Menu .....	47
8.5.1 Display Menu .....	48
8.5.2 Setup Menu.....	51
8.5.3 Range Menu.....	53
8.5.4 Menu Split Range.....	55
8.5.5 PID Menu.....	58
8.5.6 Alarm Menu .....	63
8.5.7 Action Menu.....	65
8.5.8 Mode Menu.....	66
8.5.9 FUNC Menu .....	67
8.5.10 Trim Menu .....	70
8.5.11 Lock Menu .....	72
8.5.12 Time Menu .....	74
8.5.13 T OUT MENU .....	76
8.5.14 AIR TO Menu .....	78
8.5.15 F BACK Menu.....	81
8.5.16 RESET Menu .....	82
8.5.17 VER Menu .....	84
<b>Section 9: Certifications .....</b>	<b>85</b>
9.1 Installation in Potentially Explosive Atmosphere.....	86
9.1.1 Entity Parameters.....	86
9.1.2 Example of Intrinsically Safe Connection.....	87
<b>Section 10: Mechanical Dimensions .....</b>	<b>89</b>
10.1 Rotary Positioner Dimensions.....	89
10.2 Linear Positioner Dimensions .....	90
<b>Section 11: How To Specify.....</b>	<b>91</b>

# Section 1: Introduction

The PD200 Smart valve positioner is rated IP66 and designed to operate under the most severe environmental conditions. Proportional air consumption and fast response contribute to an efficient operation and the device is unaffected by vibration.

The PD200 is compact and can be installed on rotary or linear actuators. It is utilized in applications with single or double action actuators. It is powered directly by the 4 to 20mA control current circuit and is supplied with HART communication technology.

The ES version is certified as intrinsically safe and indicated for installation in potentially explosive atmospheres of flammable gases and vapors in Class I, Div 1 & 2 environments.

## 1.1 General Notes

The positioner leaves the factory with default settings and must be installed and configured following the information in this manual. In addition, special care must be taken during transport, storage, operation and maintenance according to industrial standards and in compliance with technical regulations. This manual contains the information necessary for the proper use of the positioner. It is intended for qualified and authorized technicians who have received applicable training or have general knowledge in the field. Knowledge and technical application of the safety instructions and warnings in this manual are of utmost importance for risk-free mounting and commissioning. This will ensure safety during operation and maintenance of the product. This manual is not an integral part of the delivery of the positioner and is subject to change without notice. The manual is available for download on our website at [www.emerson.com](http://www.emerson.com).

For the sake of clarity, the manual does not contain all the detailed information on all versions of the product described, nor does it refer to all possible cases of installation, operation, maintenance and use in systems. If you need additional information, or if problems arise that are not mentioned in this documentation, please ask our technical service department for the necessary information.

Special attention must be paid to the warning texts. These texts are specially marked by their symbols. See Safe Use - User Instructions at the beginning of this document.

## 1.2 Proper Use

The PD200 positioners are electro-pneumatic position controllers intended for positioning rotary or linear final control elements and may only be used for the applications described in the instruction manual or in its data sheet. The positioner was developed in accordance with the current safety standards. Before field installation, make sure you have the correct positioner for your environment.

## 1.3 Qualified Technical Staff

Installation, configuration, and maintenance of the positioner is permitted only to technicians qualified to perform this procedure in accordance with the information in the operating instructions.

The responsible technician must be familiar with the process and be able to identify risks and avoid potential dangers during installation, setup and maintenance of the positioner.

## 1.4 Exclusion of Liability

This manual contains the most relevant information for the positioner to be mounted and configured correctly.

It is the responsibility of the technician to know the safety regulations and practices applicable in your country. It is also your responsibility to read and understand the information described here.

In case of questions, contact technical service prior to installing/configuring the positioner.

All mounting and configuration of the positioner must be performed by qualified personnel strictly following the guidelines contained in this manual.

Emerson TopWorx is not responsible for damages caused to persons or property resulting from incorrect installation and/or configuration.

## Section 2: Specifications

**Table 1 - Specifications**

### ATTENTION

When installed as an Intrinsically Safe device, refer to Section 9.1 for specifications for use in potentially explosive atmospheres.

Physical Specification	Min.	Typ.	Max.
4-20mA input Signal	3.6 mA	4-20 mA DC, Nominal	25 mA (Overcurrent Protection)
Input Voltage	12.2 VDC for analog control		35 VDC
Overcurrent Protection		Yes	
Reverse Polarity Protection		Yes	
Operation with reverse Polarity		No	
Voltage Drop		12.2 VDC @ 4 mA DC / 24 VDC	
Impedance - Input		470 Ω @ 20 mA / 24 VDC (external power supply)	
Impedance - Output		800 Ω @ 20mA / 24 VDC	
Linearity		0.8% of Full Scale	
Hysteresis		1.5% of Full Scale	
Repeatability		1.45% of Full Scale	
Minimum Step Response		≥0.3125% Full Scale or ≥50 μA	
Start-up		8 seconds	
Insulation Resistance		> 25 G [ohms] Approved in dielectric resistance test 500 VDC	
Lifetime		> 150K cycles	
Operating Temperature Limits	-40 °C (-40 °F)	LCD may not be readable below -20 °C (-4 °F)	65°C (149 °F)
Output Signal		Actuator Output from 0 to 100% of the supply pressure	
Valve Action		Double, Direct Action and Reverse Action	
SPDT Limit Switches (2)			2 A, 125VAC (Ordinary Location)
LCD-PD200		Digital – 4.5 Digit Numeric and 6 Alphanumeric Characters	
Stroke Range Linear	10mm		200mm
Shaft Rotation	60°		120°

Output Position Transmitter		<p>Nominal signal range: 4 - 20 mA</p> <p>Power Supply: 10 - 30 Vdc</p> <p>External Load Resistance: 800 Ω @ 24 Vdc</p> <p>Position Error: &lt; 0.33%</p> <p>Temperature Error Effect: 0.01%/K °C</p> <p>Resolution: &lt; 0.33%</p> <p>Output Type: Electrically isolated output</p>	
Air Supply Pressure <sup>1</sup>	40 psi (2.8 bar)		116 psi (8bar)
Maximum Bearable Pressure <sup>2</sup>			145 psi (10 bar)
Air Consumption		<p>8.8 l/min = 0.5 N m<sup>3</sup>/h = 0.31 scfm = 18.6 scfh</p> <p>considering the pressure of 60 psi = 4.1 bar</p>	
Maximum Air Output		<p>311 l/min = 17.7 N m<sup>3</sup>/h = 11 scfm = 660 scfh</p> <p>@ 60 psi (approx. 4.1 bar)</p>	
Valve Flow Characteristics		Linear, Equal Percentage, Fast Opening	
Pneumatic Connections		Supply and Output Pressure: ¼" NPT Female	
Conduit Connections		½" NPT Female	
Housing and Cover Material		SABIC LNP FARADIX DS0036I	
Display window		Polycarbonate	
Module Base Assembly		Aluminum	
Manifold		ZAMAC 5	
Elastomers		Flouroelastomer	
Protection class		IP66, Type 4X	
Weight		2.3 Kg	

**Note 1:** Or the maximum pressure allowed by the actuator.

**Note 2:** Although the positioner will resist this pressure, it is not recommended to work at this pressure as it will affect the accuracy and stability of the controller.

# Section 3: Overview

See below for parts of the PD200 positioner. To access the mechanical configuration buttons and electrical terminals, you must remove the product cover. To use the magnetic activation, it is not necessary to remove the cover.

**Figure 3-1 Overview**

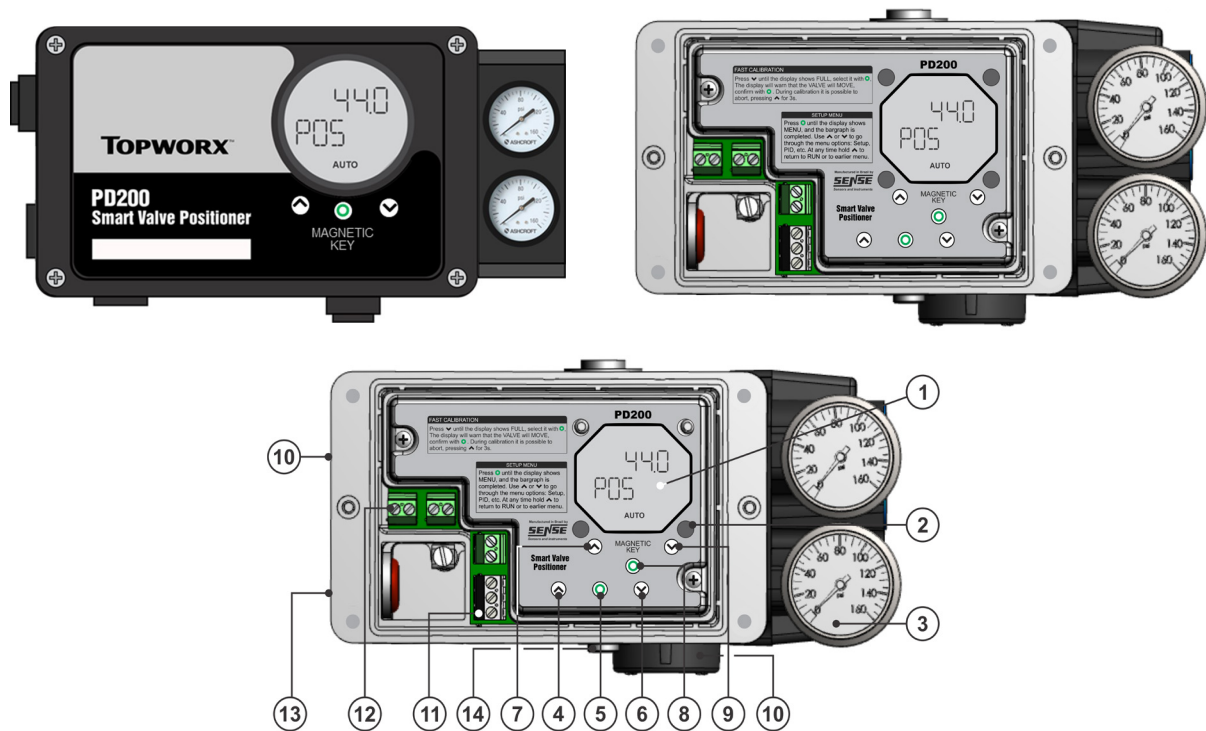

**Table 2 - Part Description**

Item	Description
1	LCD Display 5 numeric digits and 6 alphanumeric
2	Plate Cover
3	Manifold with Pressure Gauges
4	Mechanical UP Button
5	Mechanical ENTER Button
6	Mechanical DOWN button
7	Magnetic UP Button
8	Magnetic ENTER Button
9	Magnetic DOWN button
10	Air Exhaust
11	Electrical Terminals (Input and Output Signals)
12	Electrical Terminals (Alarm)
13	Cable Entry

### 3.1 Enclosure

Enclosure manufactured with conductive type resin. This allows the housing to be grounded to avoid the accumulation of electrostatic charges that in classified areas can cause the ignition of the explosive atmosphere.

Figure 3-2 Enclosure

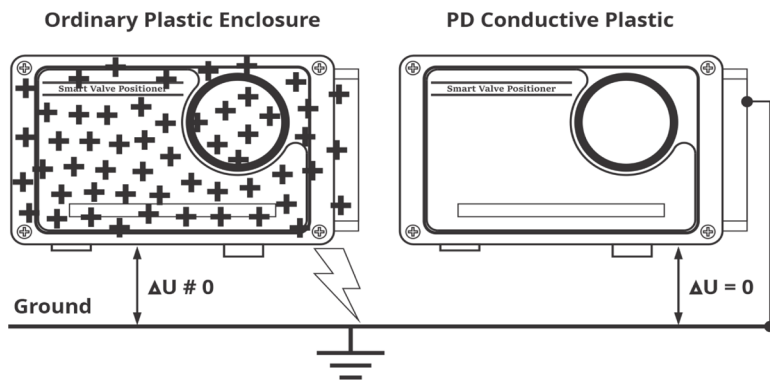

### 3.2 Identification Label Information

These labels have information about the positioner such as coding, serial number, manufacturer, and certification information, among other information described below:

Figure 3-3 Front Label



Figure 3-4 Side Label

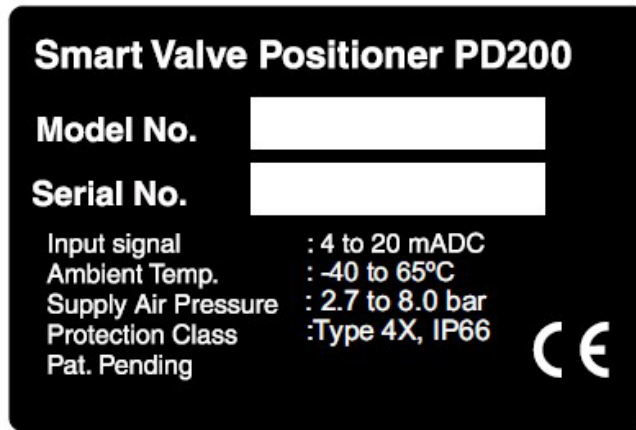

Figure 3-5 Internal Label

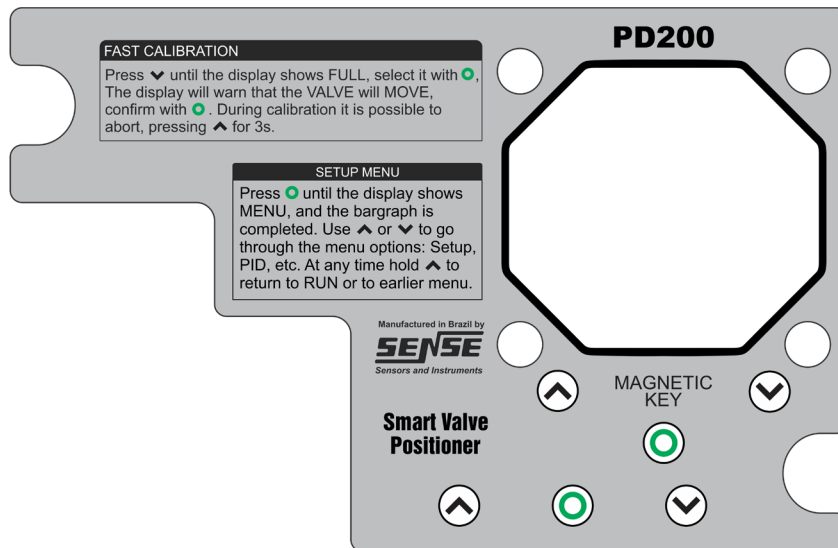

Figure 3-6 Certification Label



**Front Label**

This label contains the following information:  
Manufacturer ID  
Order code

**Side Label**

This label carries the following information:  
Model number  
Serial Number  
Operation and certification Information

**Internal Tag**

This label contains the following information:  
Terminal identification  
How to perform a quick calibration  
How to enter and navigate the configuration menu

**Certification Label**

This label contains the following information:  
UL Listed USL/CNL report number  
Hazardous area certification details  
Intrinsically safe entity parameters

### 3.3 Manipulated Variable

The Manipulated Variable (MV) represents the force exerted by the electro-pneumatic system of the positioner to maintain balance at the control point. This force is the result of all the internal subsystems of the positioner.

The MV adjustment is found on the side of the housing, protected by a screw. This adjustment is initially set at the factory during production to balance the forces on the internal components. It should only be readjusted by a qualified technician at the factory, following maintenance or replacement of any internal component.

**Figure 3-7 MV Adjustment Location**

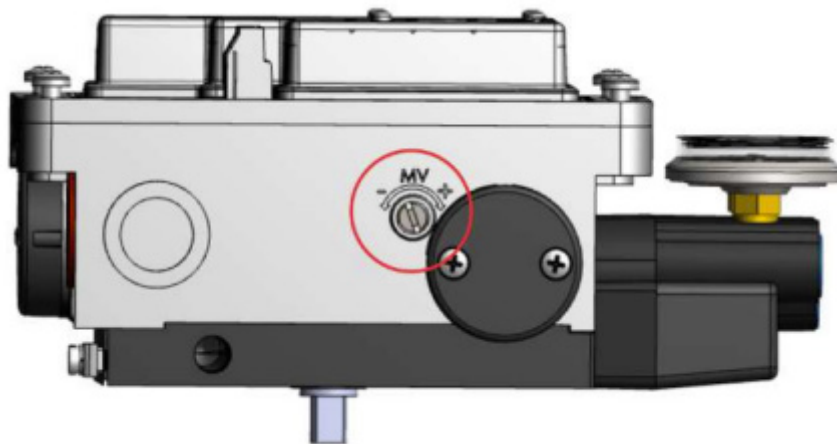

#### NOTICE

Avoid adjusting the MV setting, as doing so can disrupt the balance of forces within the positioner's internal subsystems. This imbalance can impair its operation, causing errors in valve positioning or even making the system unstable, potentially resulting in a loss of process control.

## 3.4 Scope of Supply

Check the packaging immediately after receiving the product. Make sure that the contents are undamaged and that they are in accordance with the scope of delivery and as described on the invoice. If there are any discrepancies, please contact us immediately.

The positioner is supplied in a closed package containing the following items:

- Intelligent electropneumatic positioner
- Linear or rotary actuator adaptor (as specified)
- Magnetic keychain for function configuration

## Section 4: Principle of Operation

The PD200 smart positioner is powered by the 4-20 mA loop, with the control signal.

The Supply Air is connected to the inlet on the manifold and passes through the pneumatic spool valve that controls the valve position.

The air passes through the **Pressure Regulator** and reaches the **I/P Converter**.

The valve position is detected through the **Position Feedback Sensor** (Hall effect sensor) and transmitted to the electronic board (**Main Microprocessor**). The fast microprocessor compares the control signal and the position feedback, and the difference is the input to the PID controller that will generate an appropriate signal (in frequency) to be applied to the coil of the I/P converter.

The **I/P Converter** is a nozzle/vane that generates a pressure signal to the **Diaphragm Module**. This will create a dynamic force on the spring that breaks the balance of the spool valve, that then moves the valve to the new required position.

The microcontroller repeats the process. When the difference between the requested position signal and the actual position feedback trends to zero, the interference of the Diaphragm Module will cease. There will be a new balance on the spool valve and the valve will reach the new position.

Figure 4-1 Operating Principle

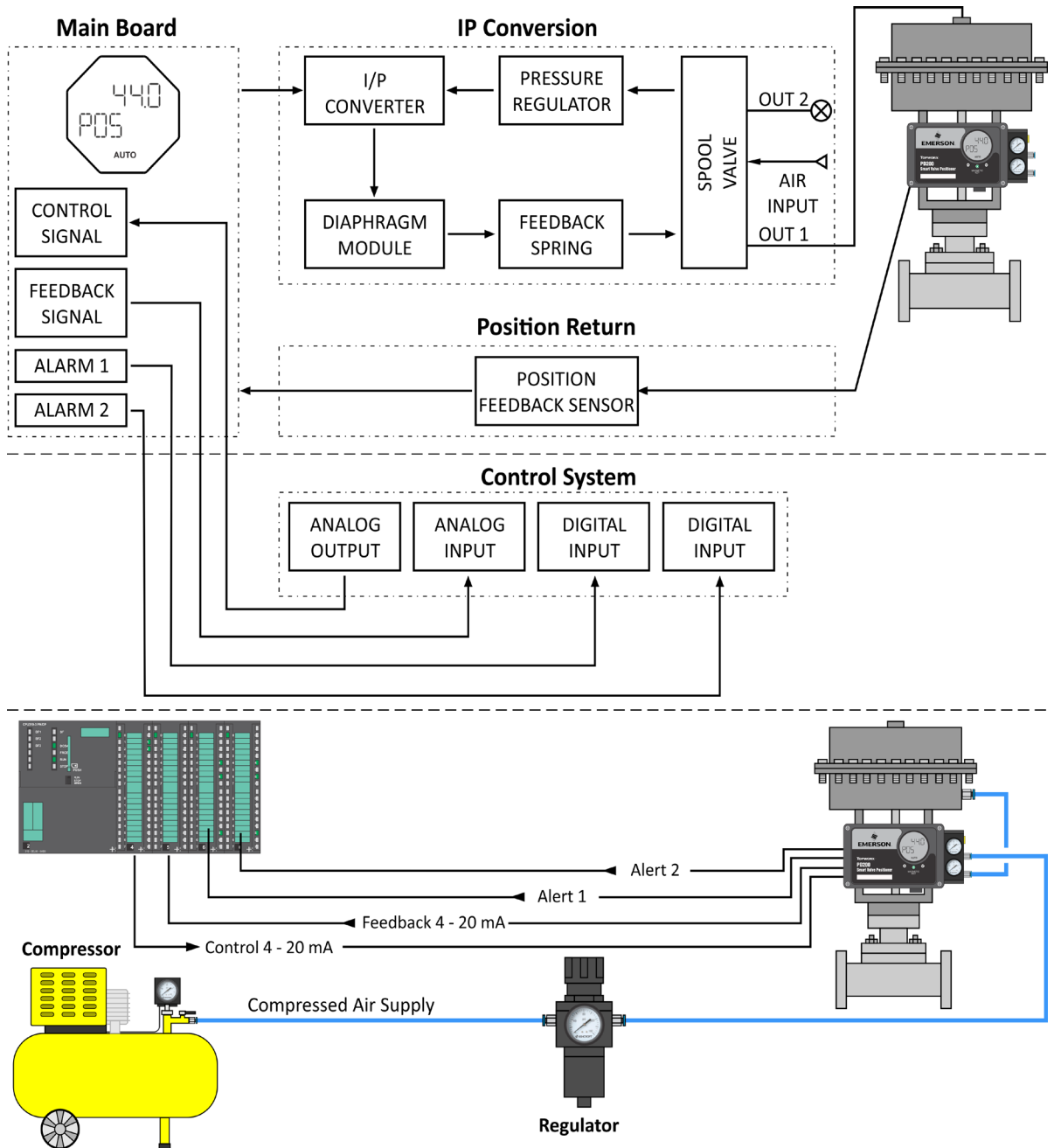

## Section 5: Mechanical Installation

The installation of the positioner will depend on the actuator type (linear or rotary). The following shows the types of pneumatic actuators and a brief overview of their operation.

Be sure to install the air filter and regulator before the positioner. The supply pressure should be sufficient to fully open and close the valve.

### 5.1 What are Rotary Pneumatic Actuators?

Rotary pneumatic actuators are devices that convert the stored energy of compressed air into a rotary mechanical motion. These devices can be single-acting, where they receive air to open or close the valve and return to their original position by means of a spring, without the need for air, or double-acting, which requires compressed air to move in both directions.

**Figure 5-1 Rotary Actuator Types**

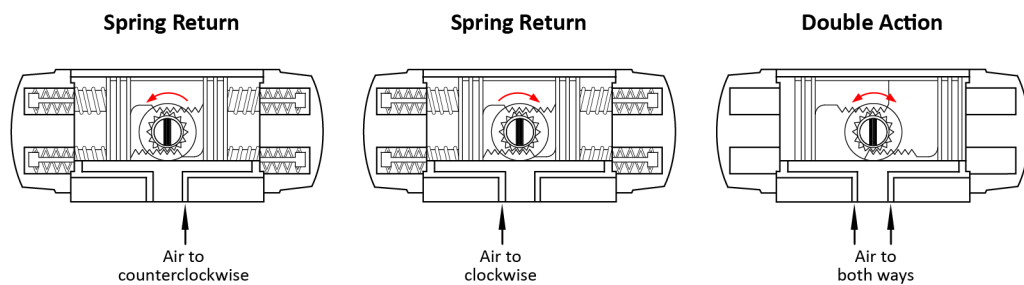

### 5.2 What are Pneumatic Linear Actuators?

Linear pneumatic actuators are devices that convert the stored energy of compressed air into a linear mechanical motion. This linear motion allows the valve to open or close.

Similarly, to rotary actuators, they can also be single-acting, requiring air for only one direction, or double-acting, requiring air for both directions.

**Figure 5-2 Linear Actuator Types**

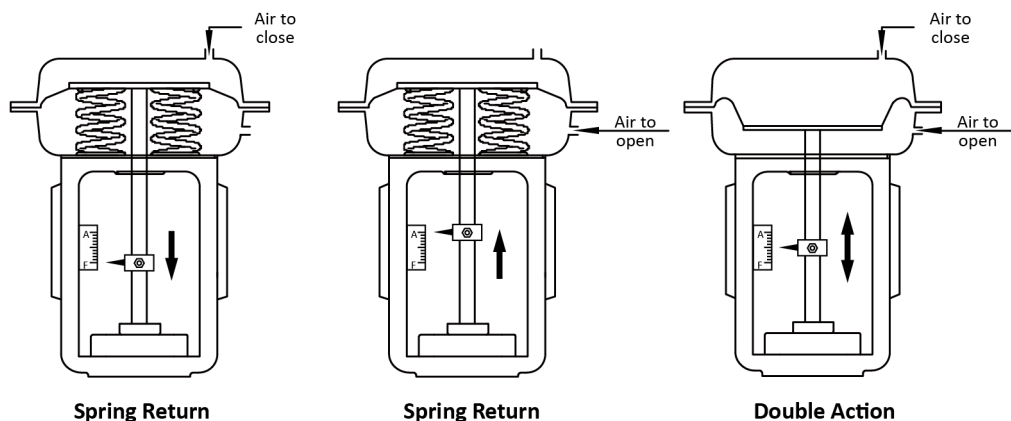

## **⚠ WARNING**

Observe the maximum pressure that the pneumatic actuator can withstand. Diaphragm actuators can be easily damaged by excessive pressure.

## 5.3 Rotary Actuator Installation

Figure 5-3 Installation on a Rotary Actuator



### **IMPORTANT**

When installing the mounting bracket on the positioner and then setting on the rotary pneumatic actuator, observe the maximum torque indicated below:  
Positioner on the mounting brackets (4xM6): 10 Nm (7.38 ft/lbs.).  
Mounting bracket on the rotary actuator (4xM5): 10 Nm (7.38 ft/lbs.).

### **ATTENTION**

Before installing the positioner, check the area classification. Never use a General Purpose positioner in an area classified as an explosive atmosphere.

### Figure 5-4 Mounting Kit for Rotary Actuator

Depending upon the NAMUR mounting dimensions required, one of the existing TopWorx ISO/NAMUR quarter-turn rotary actuator VIP mounting kits, as listed below, will work with the PD Series Positioners.

For any other mounting pattern request, please contact your Emerson representative.

Shaft Height (H)	Mounting Hole Pattern Length (L)	
	80 mm	130 mm
20 mm	4N20080-G41S	N/A
30 mm	4N30080-G41S	4N30130-G41S
50 mm	N/A	4N50130-G41S

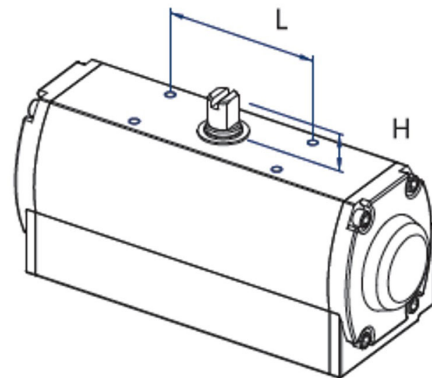

## 5.3.1 Mounting the Rotary NAMUR Bracket to the Actuator

### IMPORTANT

Check the L and H position for correct mounting of the positioner to the pneumatic actuator.

- 1 - Mount the rotary adapter and tighten the screw with an 8 mm hex wrench.

### Figure 5-5 Rotary Adaptor

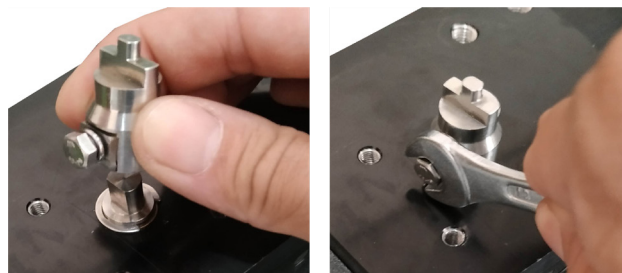

- 2 - The rotary support is factory assembled for actuators with 30x80 holes and 30mm shaft height. If you need to modify, refer to Section 5.3.1 - Mounting the Rotary Support According to the Actuator.

- 3 - Mount the bracket to the positioner by placing the four M6x10 screws with lock washers and plain washers. Tighten the screws with a 10 mm wrench.

**Figure 5-6 Mounting the Bracket on the Positioner**

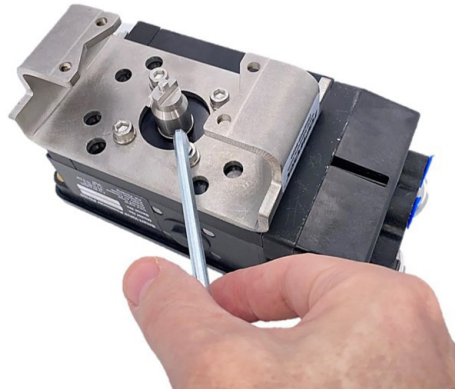

### ATTENTION

Do not touch the actuator shaft when it is running, as moving it may cause accidents with serious injuries.

### CAUTION

Be careful when handling compressed air hoses, make sure the line is disconnected before connecting it to the positioner.

### IMPORTANT

The positioner can be installed at any starting angle and operates in any position, vertical or horizontal.

4 - Mount the positioner with bracket by engaging the positioner end cap on the shaft of the rotary actuator, attach the four M5x10 screws with lock washers and plain washers. Tighten the screws with an 8 mm wrench.

**Figure 5-7 Fitting on the Actuator Shaft**



---

**Figure 5-8 Tightening the Bracket Bolts**



---

5 - Make the pneumatic and electrical connections. See Section 6 - Pneumatic Connections and Section 7 - Electrical Connections.

6 - Perform a fast calibration. See Section 8.3 - Fast Calibration.

---

**Figure 5-9 Mounted Positioner**



## 5.4 Linear Actuator Installation

See below the installation of the positioner on linear valves.

**Figure 5-10 Installation on a Linear Actuator**



### **⚠ DANGER**

Before installing the positioner, check the area classification. Never use a General Purpose positioner in an area classified as an explosive atmosphere.

### **⚠ WARNING**

Excess pressure can permanently damage the actuator diaphragm. Check the actuator manual for the maximum pressure supported.

### **IMPORTANT**

When installing the mounting bracket on the positioner and then setting on the linear pneumatic actuator, observe the maximum torque indicated below:  
Positioner on the mounting brackets (2xM8): 15 Nm.  
Mounting bracket on the linear actuator (2xM8): 15 Nm.

## 5.4.1 Mounting the Guide Lever

Figure 5-11 Assembling the Guide Arm

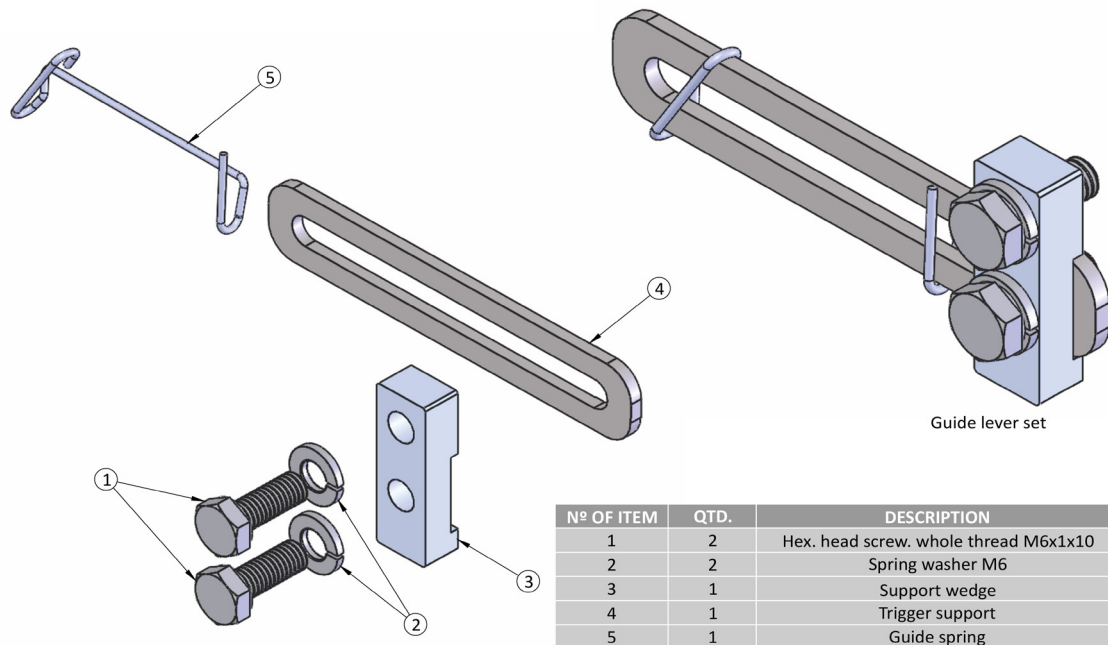

## 5.4.2 Installation of the Feedback Lever and Support

Figure 5-12 Installing the Feedback Lever and Support

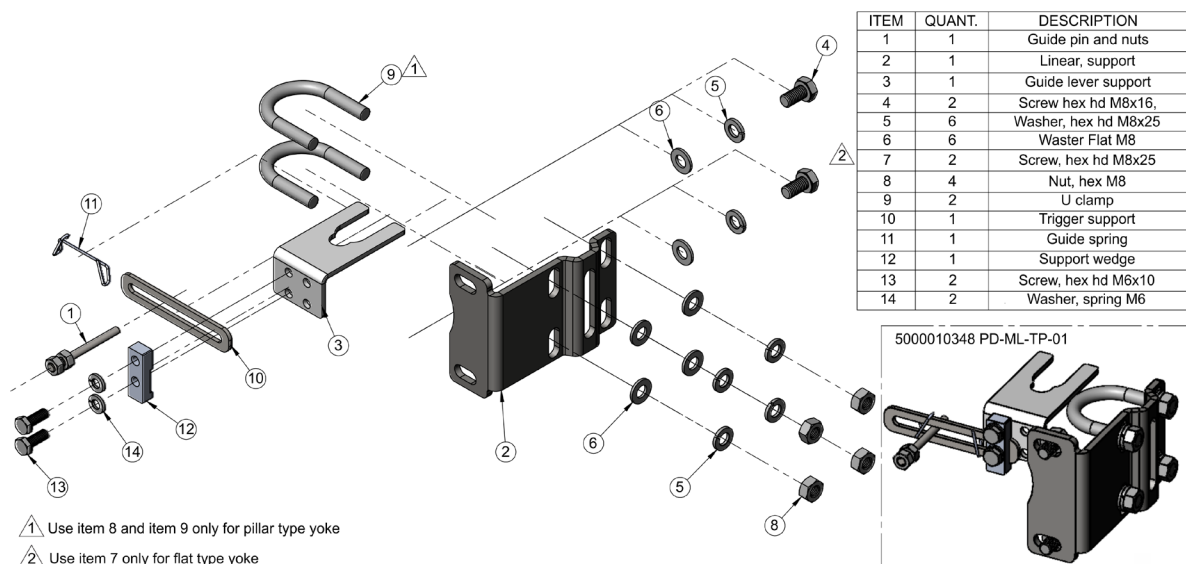

### IMPORTANT

The feedback lever is graduated. Check the maximum valve travel for correct assembly of the guide pin. Refer to Section 5.4.5 - Feedback Lever Types.

### 5.4.3 Yoke Castle Mount

Figure 5-13 Yoke-Type Bonnet Assembly

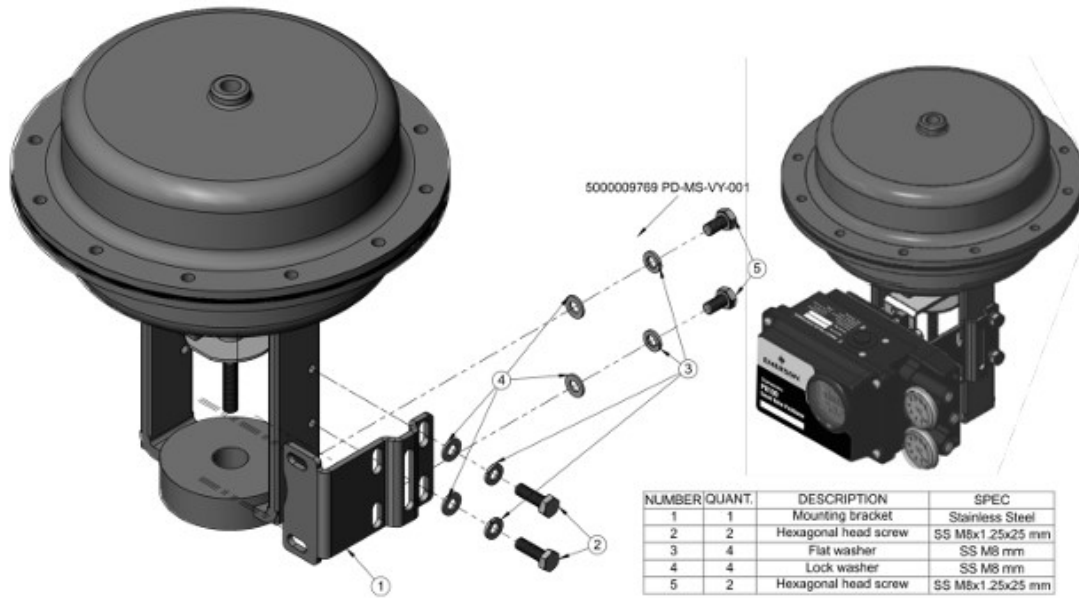

### 5.4.4 Mounting on a Pillar Type Castle

Figure 5-14 Mounting on a Pillar-Type Castle

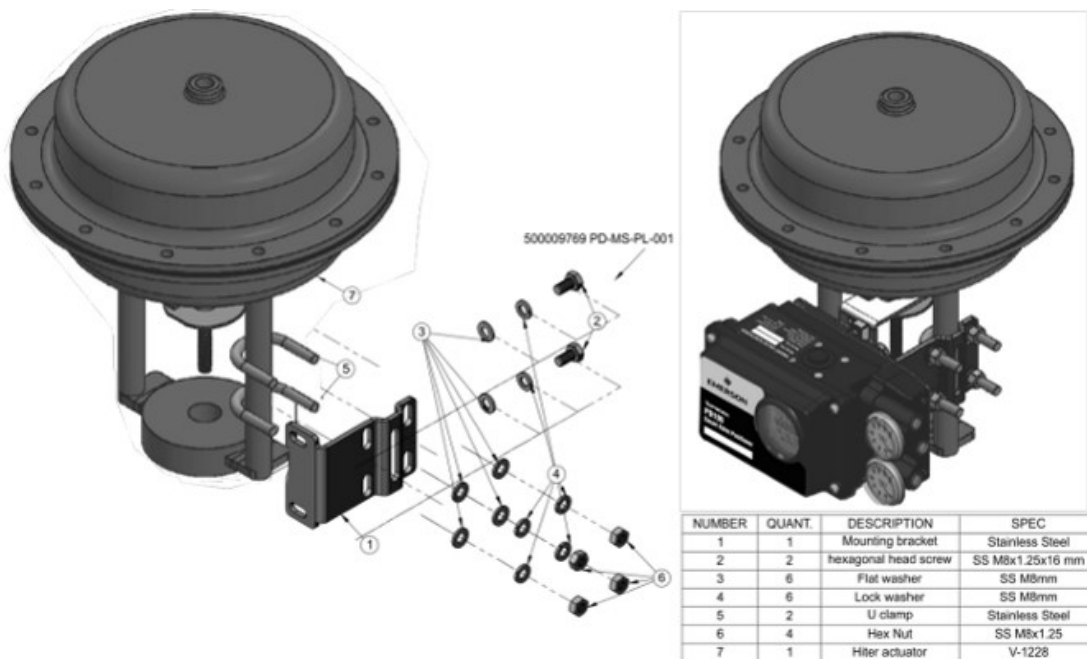

**⚠ DANGER**

Before installing the positioner, check the area classification. Never use a General Purpose positioner in an area classified as an explosive atmosphere.

## 5.4.5 Feedback Lever Types

The feedback levers are classified by two stroke lengths (K3, and K4), which are directly linked to the minimum and maximum operating stroke.

**Figure 5-15 Feedback Lever Types**

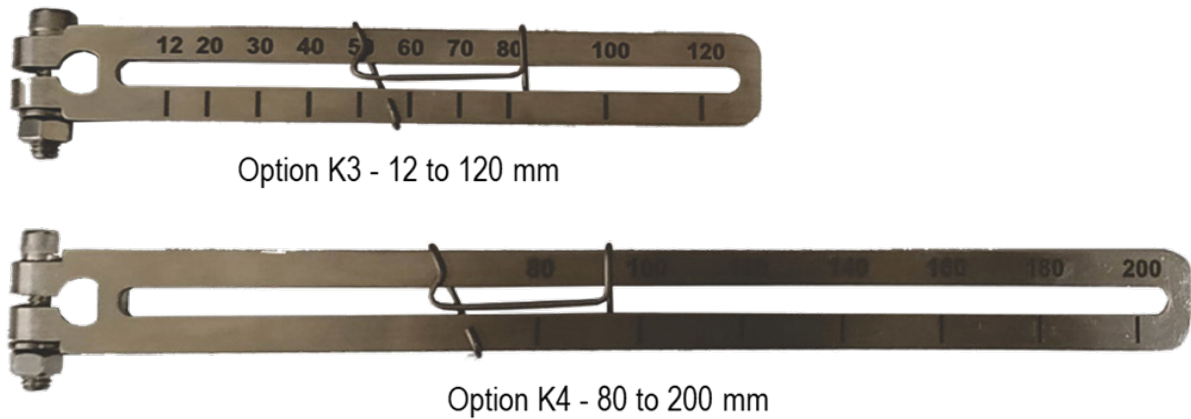

### IMPORTANT

Check the maximum valve travel to use the correct feedback lever. For mounting the lever see: Section 5.4.2 - Installation of the Feedback Lever and Support

## 5.4.6 Standard Installation

The following procedure refers to standard yoke-type bonnet installation. It is important to remember that regardless of the type of yoke, the positioner must operate within the angle range of  $-30^\circ$  to  $+30^\circ$ , totaling  $60^\circ$ .

**Figure 5-16 Angles of Operation**

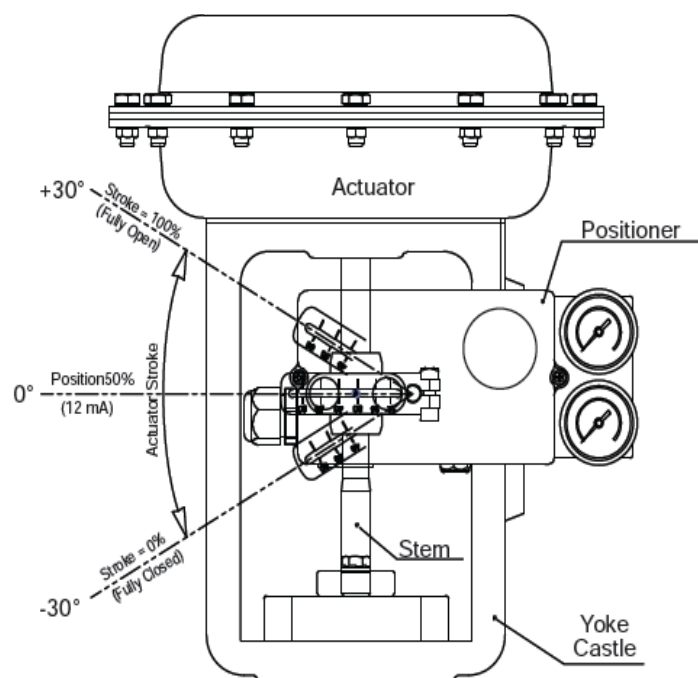

---

**IMPORTANT**

If the positioner operates with an angle smaller than  $\pm 30^\circ$  the accuracy will be considerably affected.

---

1 - Perform a test by applying compressed air directly to the valve through a pressure regulating valve. To check the maximum and minimum stroke, start by applying 0% (valve closed). Slowly increase the pressure until the valve reaches 100% of its stroke.

For the positioner assembly, it is recommended to release the air through the regulator so that the valve reaches 50% of its full stroke.

---

**Figure 5-17 Testing the Positioner's Travel and Mounting Position**

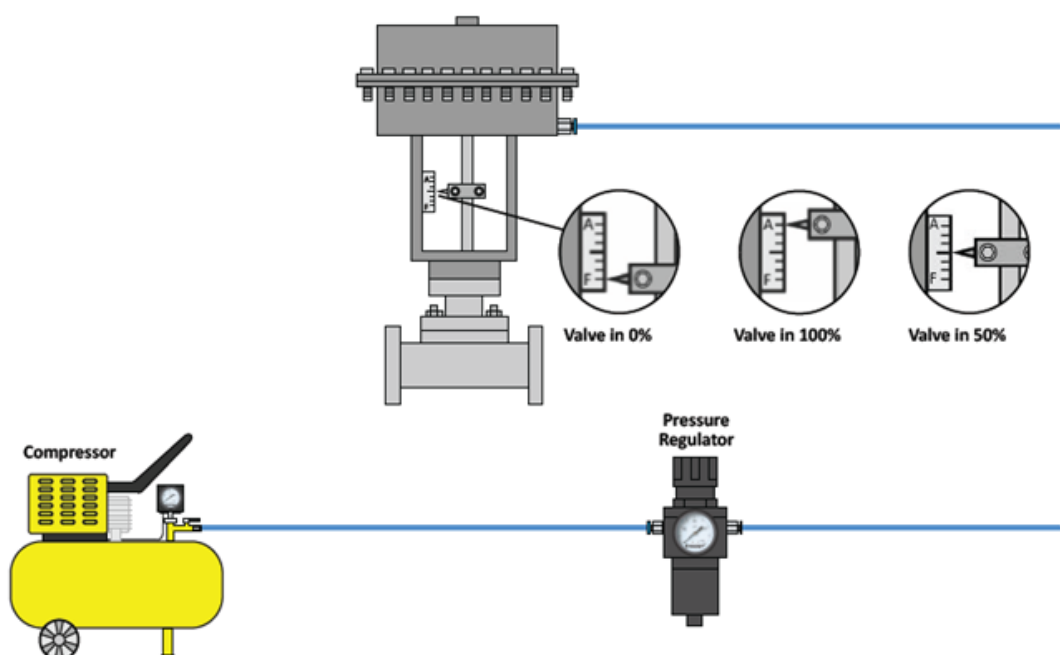

---

**⚠ CAUTION**

Caution when handling compressed air hoses, make sure the line is disconnected before connecting it to the positioner.

---

2 - Install the feedback lever on the positioner shaft. Tighten the setscrew with a 5 mm hex wrench.

---

**Figure 5-18 Installing the Feedback Lever**

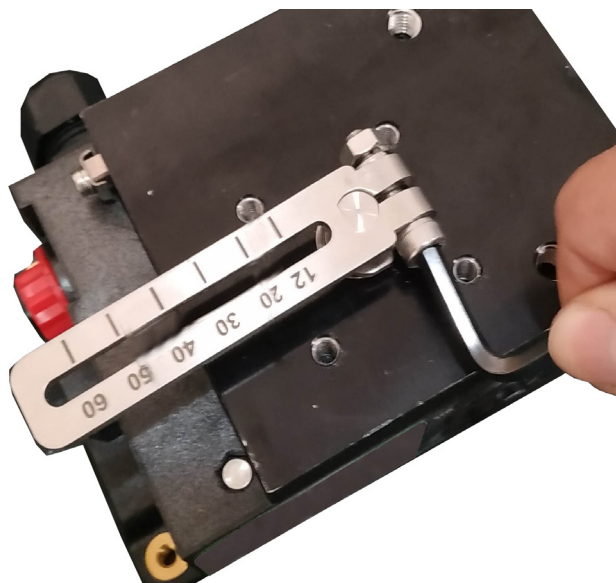

---

**IMPORTANT**

The assembly can be performed with the valve at 0% (fully closed) or 100% (fully open). Pay attention to the 60° operating angle range (from -30° to +30°).

3 - Install the bracket on the bottom of the positioner with the two M8 screws, plain and spring washers. Securely tighten the screws with a 13 mm hex wrench.

---

**Figure 5-19 Installing the Mounting Bracket**

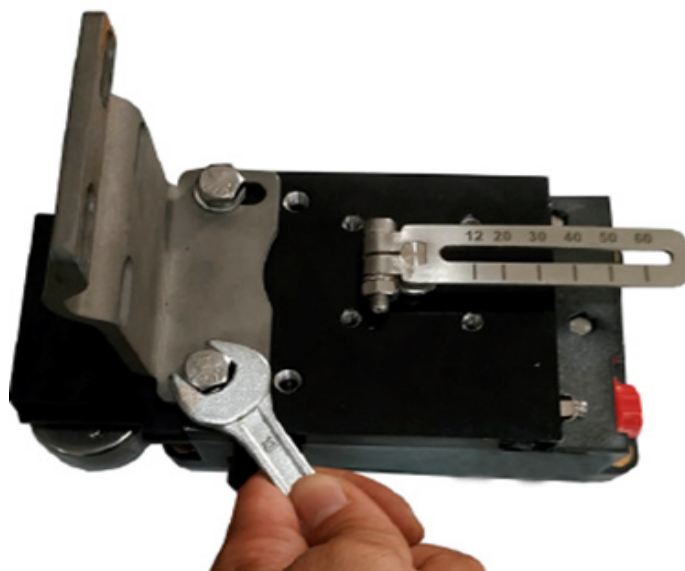

4 - Install the guide pin in the feedback lever, observing the maximum travel of the valve. Tighten the retaining nut with a 10 mm hex wrench.

**Figure 5-20 Installing the Dowel Pin**

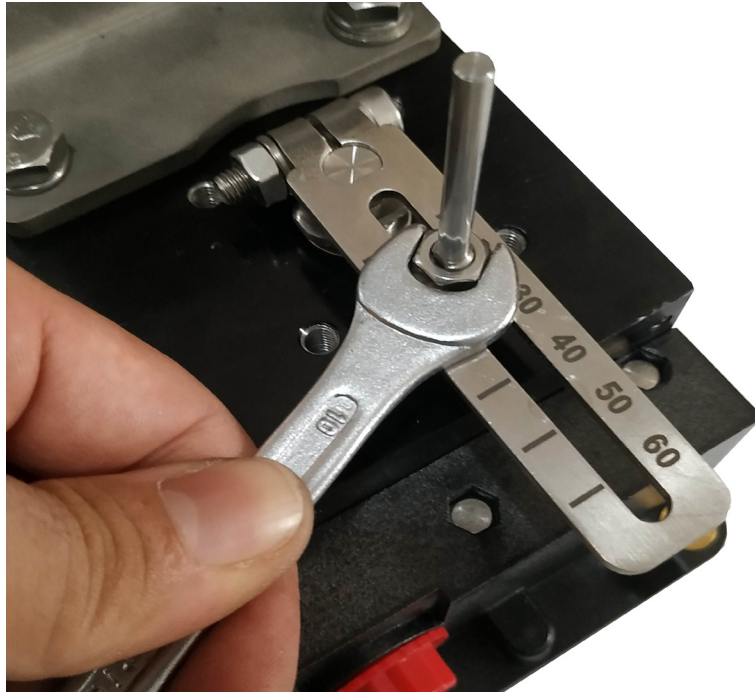

**Figure 5-21 Guide Pin in the Correct Position (Valve Travel)**

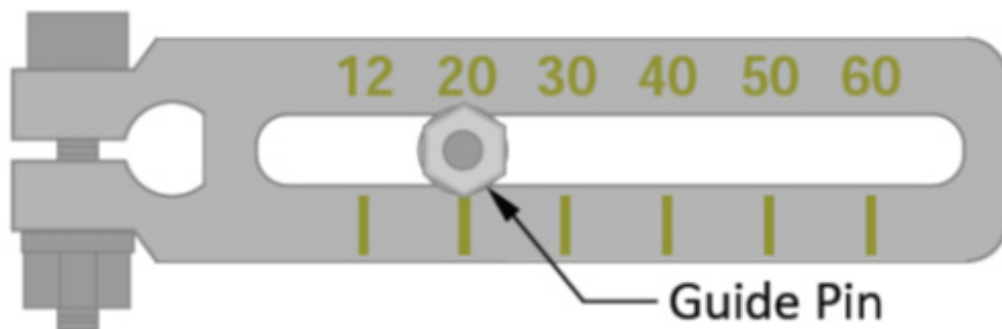

5 - Install the guide arm on the valve stem. Tighten the screws with a 10 mm hex wrench.

---

**Figure 5-22 Installing the Guide Arm on the Valve Stem**



---

6 - Install the positioner with bracket onto the valve bonnet, using M8x16 screws. The guide pin should pass through the middle of the guide arm. Do not fully tighten the screws, to allow adjustment of the feedback lever. Move the bracket up and down until the feedback lever is parallel to the guide arm.

---

**Figure 5-23 Setting the Feedback Lever**

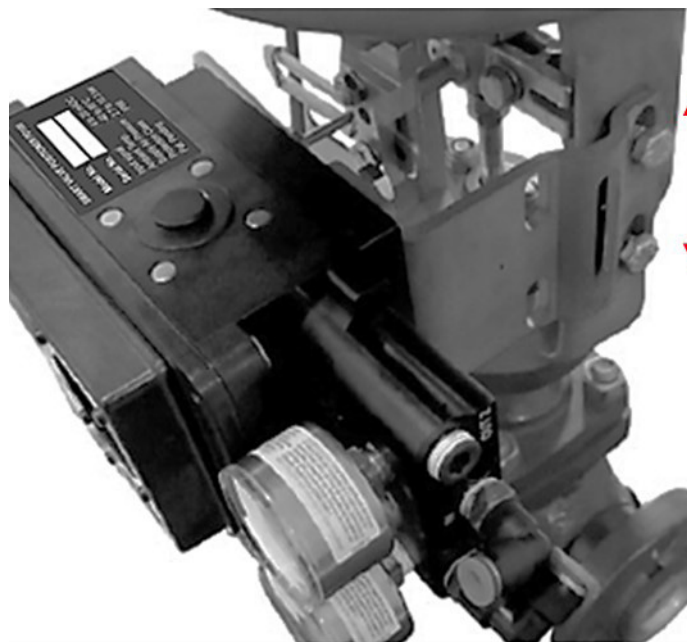

---

**Figure 5-24 Feedback Lever and Guide Arm**

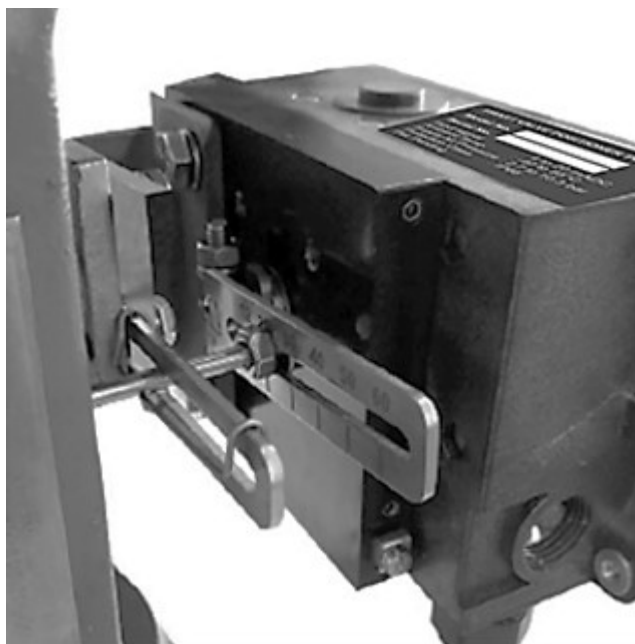

---

7 - After adjusting the feedback lever, tighten the bracket screws firmly with a 13 mm hex wrench.

8 - Make the pneumatic and electrical connections. See Section 6 - Pneumatic Connections and Section 7 - Electrical Connections.

9 - With all connections made, perform the auto-calibration process. See Section 8.3 - Fast Calibration.

### **ATTENTION**

Risk of crushing and shearing with mounting kits that use a lever for position detection. During commissioning and continuous operation, cuts or compression of the limbs can occur in case of physical contact with the moving parts of the system.

### **⚠ WARNING**

The maximum pressure in the line after the regulator and before it enters the positioner **MUST NOT** be greater than the actuator can support (to avoid damaging it).

---

### **IMPORTANT**

The screws of the bracket, guide arm and feedback lever must be tightened firmly to avoid errors during the positioner calibration process.

---

## Section 6: Pneumatic Connections

Instrument air must be of better quality than industrial compressed air. Humidity, suspended particles, and oil can impair the instrument's operation temporarily or permanently if internal parts wear out.

### **⚠ WARNING**

Impurities in the supply air can partially or completely damage the positioner's internal components. Before connecting the conduit, it is essential to remove dust, oil, or other impurities.

### **IMPORTANT**

Before instrumentation air is connected to the positioner, we recommend that the hose be opened freely for 2 to 3 minutes to allow any contamination to escape.

### **⚠ WARNING**

A pressure exceeding 10 bar (145 psi) may permanently damage the positioner. Measures must be taken to ensure that even if the compressed air supply fails, the pressure does not exceed 10 bar (145 psi).

**Figure 6-1 Location of the Pneumatic Connections**

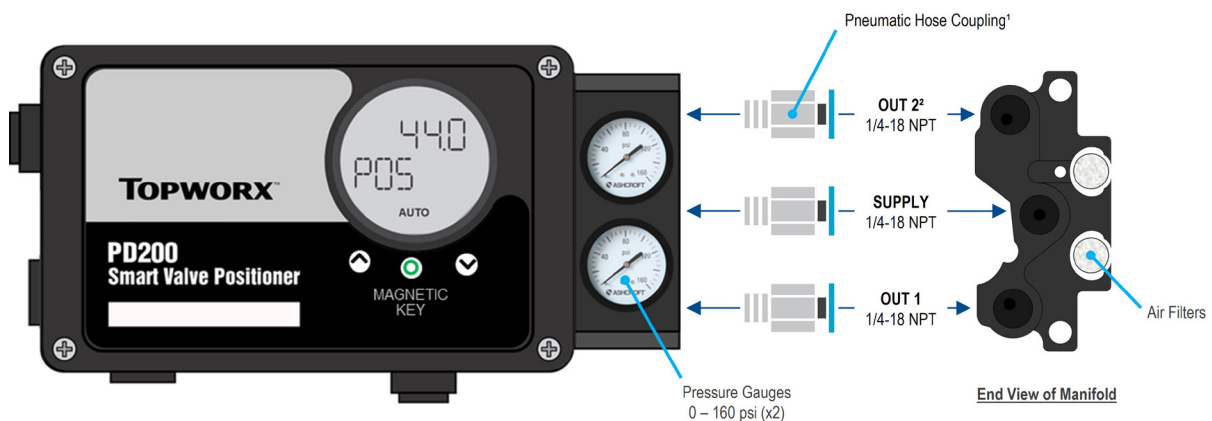

All pneumatic connections are on the right side of the positioner. Threaded holes are available for pneumatic connections. All connections are marked and their NPT standards must be observed. Connectors for pneumatic hoses are not supplied with the positioner.

See connections according to table below:

**Figure 6-2 Description of the Pneumatic Connections**

Connection	Utilization
IN	Input pressure connection (2.8 to 8 bar)
OUT 1	Output pressure 1 (single-acting actuators)
OUT 2	Output pressure 2 (double-acting actuators)

**IMPORTANT**

The positioner's operating pressure is 2.8 to 8 bar (40 to 116 psi), but the actuator may operate with a different pressure. Unused outputs must be plugged. Refer to Section 6.2 and 6.3.

**⚠ WARNING**

We recommend installing a pressure regulating filter between the pneumatic line and the positioner's pressure inlet connection. High pressures may damage both the positioner and the valve actuator.

## 6.1 Manifold Types

The PD200 positioner is supplied with one type of manifold for pneumatic connection which includes two pressure gauges.

**Figure 6-3 Long Manifold with Gauges**

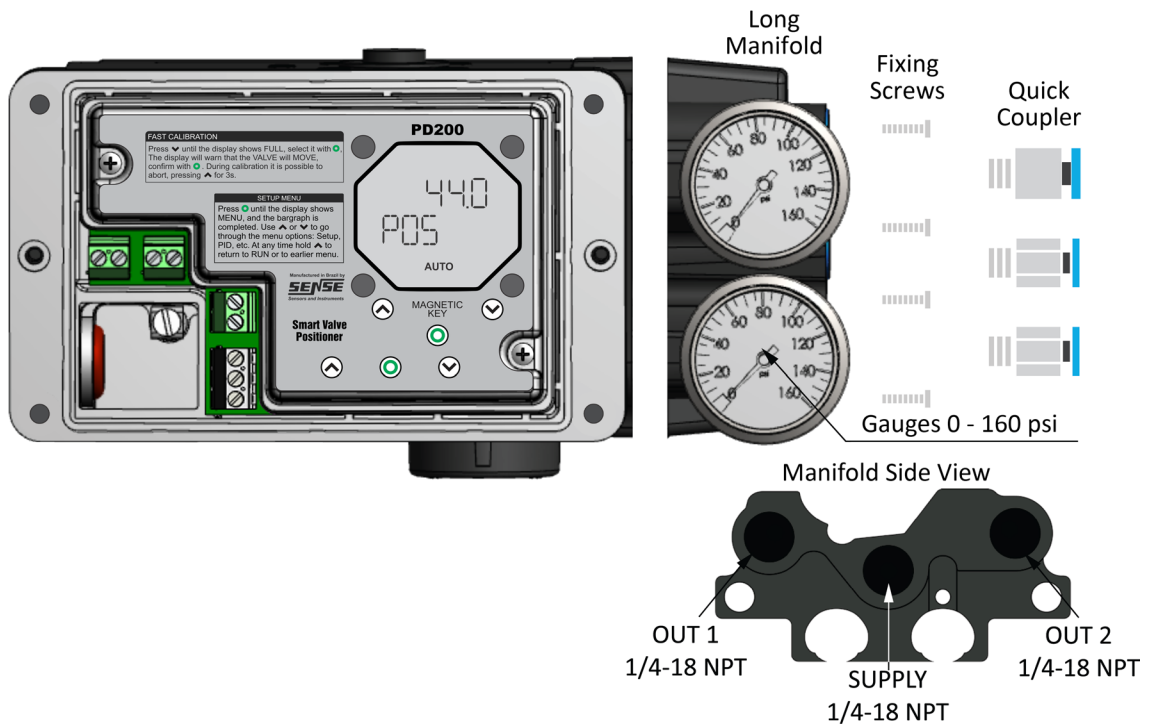

**IMPORTANT**

Pneumatic hose couplings are not supplied with the positioner.

## 6.2 Pneumatic Connection on Rotary Actuator

Check below the pneumatic connection for each type of rotary actuator.

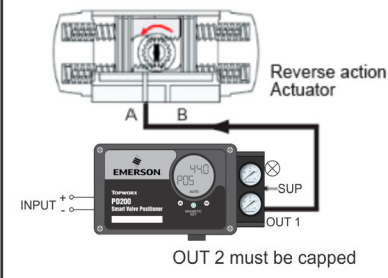
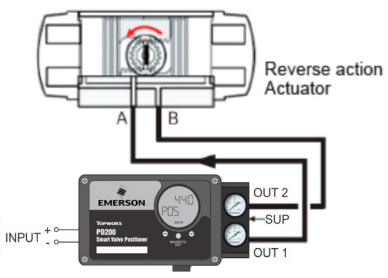
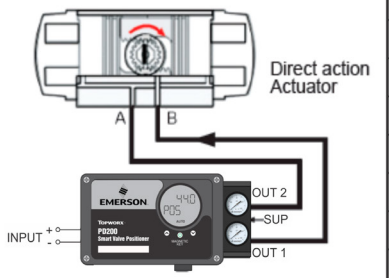
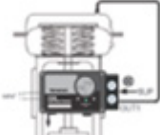
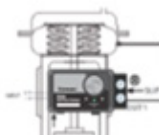
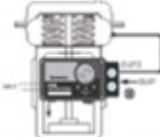
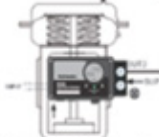

**Figure 6-4 Pneumatic Connections on Rotary Actuators**

	Spring Return	Double Action - RA	Double Action - DA
	 <p>Reverse action Actuator</p> <p>OUT 2 must be capped</p>	 <p>Reverse action Actuator</p>	 <p>Direct action Actuator</p>
	As the input signal increases, the actuator shaft rotates counterclockwise.	As the input signal increases, the actuator shaft rotates counterclockwise.	As the input signal increases, the actuator shaft rotates clockwise.
	<b>Spring Return</b>		<b>Double Action</b>
<b>Direct Action</b>	Out 1: connected Out 2: buffered	Out1: connected to port B of the actuator Out2: connected to port A of the actuator	
<b>Reverse Action</b>	Out 1: buffered Out 2: connected	Out1: connected to port A of the actuator Out2: connected to port B of the actuator	

## 6.3 Pneumatic Connection on Linear Actuator

Check below the pneumatic connection for each type of linear actuator.

**Figure 6-5 Pneumatic Connections on Linear Actuators**

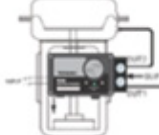
Direct Action		Reverse Action	
<p><b>DA 1</b>                      As the input signal increases, the valve stem moves downward.</p>  <p>OUT 2 must be capped</p>	 <p>OUT 2 must be capped</p>		
<p><b>DA 2</b>                      As the input signal increases, the valve stem moves downward.</p>  <p>OUT 1 must be capped</p>	<p><b>RA 2</b>                      As the input signal increases, the valve stem moves upwards.</p>  <p>OUT 1 must be capped</p>		
<p><b>DA 3</b>                      As the input signal increases, the valve stem moves downward.</p> 	<p><b>RA 3</b>                      As the input signal increases, the valve stem moves upwards.</p> 		
	Spring Return		Double Action
Direct Action	DA1: Out 1: connected at the top DA2: Out 2: connected at the bottom		DA3: Out1: connected at the top Out 2: connected at the bottom
Reverse Action	RA1: Out 1: connected at the bottom RA2: Out 2: connected at the top		RA3: Out1: connected to the bottom Out 2: connected at the top

### IMPORTANT

The unused outlet must be capped.

## Section 7: Electrical Connections

### 7.1 Cable Entry

---

#### IMPORTANT

The cable terminals are supplied in a closed state and must be unscrewed before inserting the cables.

---

The positioner has one 1/2" NPT entry. Cable glands are not included.

---

**Figure 7-1 Cable Gland and Plug**

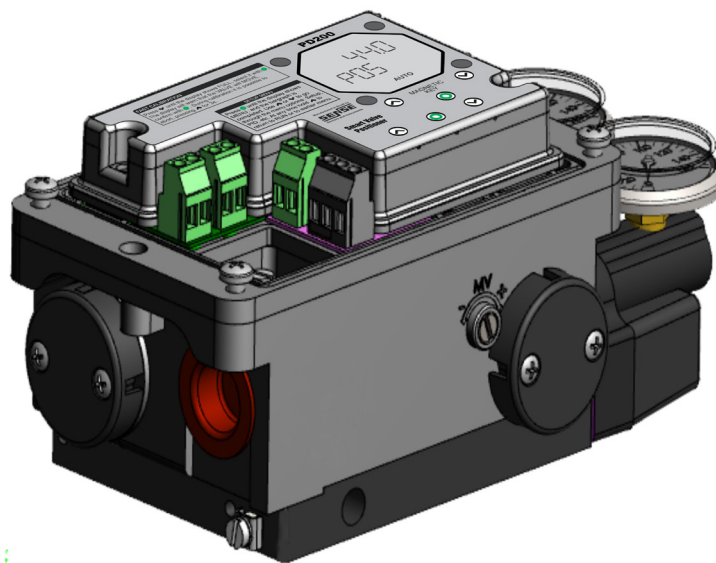

---

#### **⚠ DANGER**

Hazardous area equipment must not operate with cable entries open.

---

#### **⚠ DANGER**

The positioner must not operate in a hazardous area without its cover correctly installed.

- 1 - The cable gland should be installed as in the picture above.
  - 2 - Turn the cover of the cable gland counterclockwise to open and insert the wires.
  - 3 - Connect the wires to the terminals and tighten the cable gland.
-

---

**IMPORTANT**

- Use cables with a maximum diameter of 12 mm and a minimum diameter of 9 mm.
  - Be sure to de-energize the power source before connecting the cable.
  - Always use the plug in the unused cable entry to prevent objects or liquids from entering into the enclosure.
- 

## 7.2 Grounding

Grounding the positioner is extremely important and highly recommended. Two grounding points are provided, one internal and one external. If the cable used is shielded, it is recommended that the shield be grounded at one end only. The ungrounded end should be carefully isolated.

---

**Figure 7-2 Grounding Terminal Blocks**

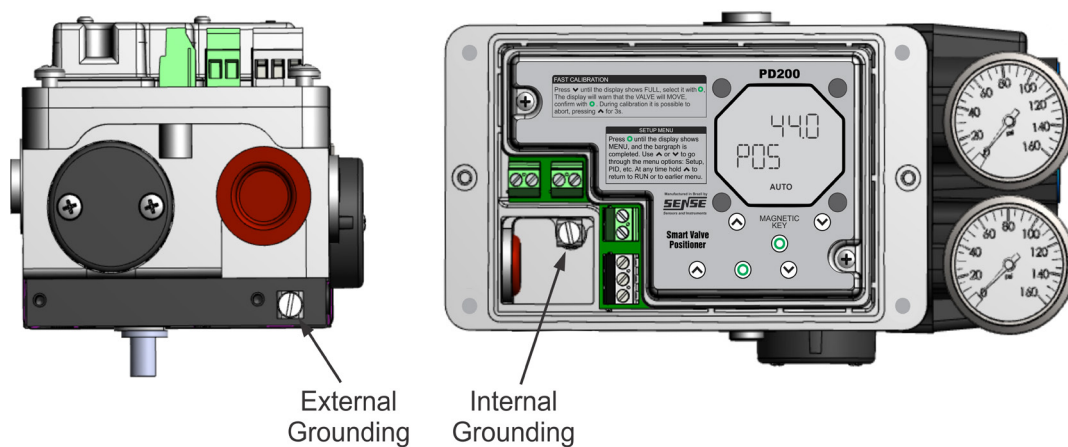

## 7.3 Electrical Connection

The PD200 is equipped with screw terminals intended for connection of the control signal and feedback signal, along with a terminal for the limit switch outputs.

**⚠ WARNING**

Be sure to supply the rated voltage and current indicated in this manual (see Section 2 - Specifications and Section 9.1 - Entity Parameters). Failure to do so may cause serious damage or malfunctioning of the positioner.

- When it is necessary to open the positioner's cover in a damp location, great care must be taken. This may cause serious damage or malfunction of the electronic circuitry.
-

**Figure 7-3 Electrical Connection with Micro Switches and Feedback with active Input Card**

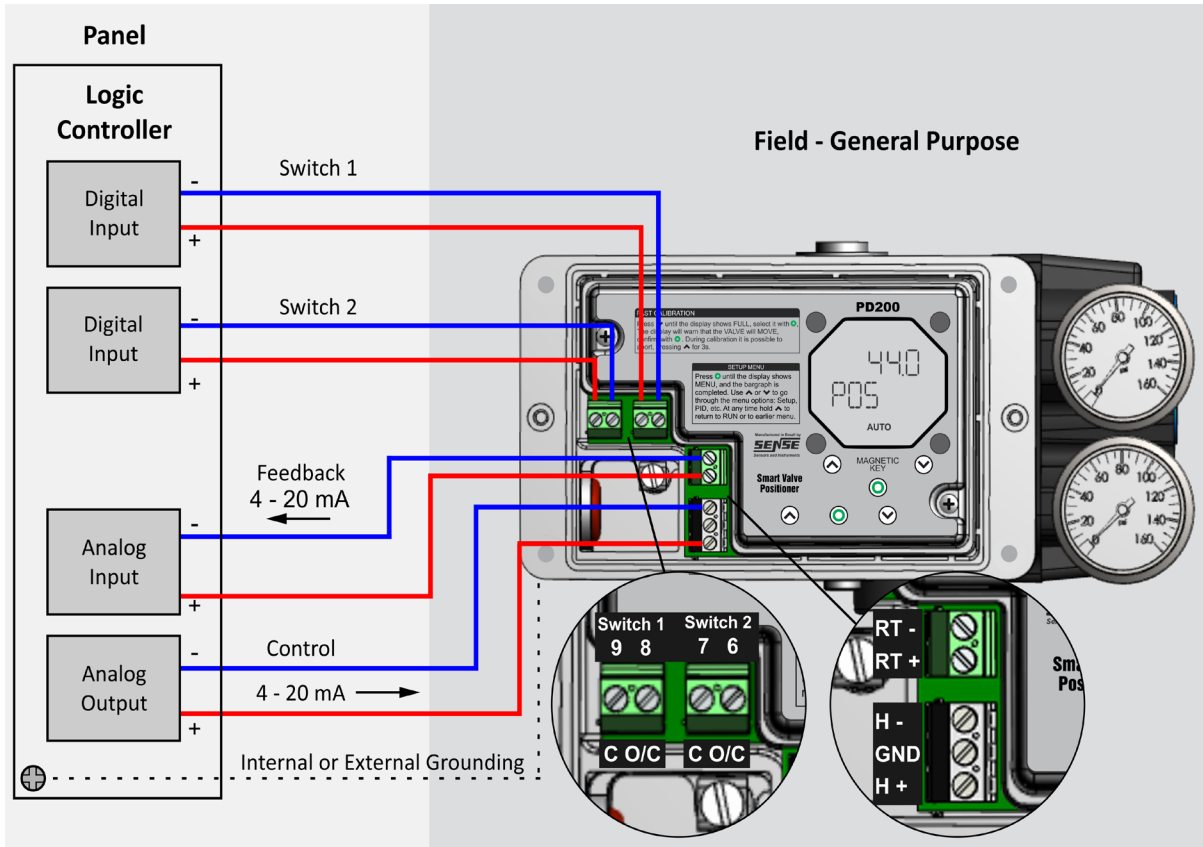

**Figure 7-4 Electrical Connection for Split Range Operation**

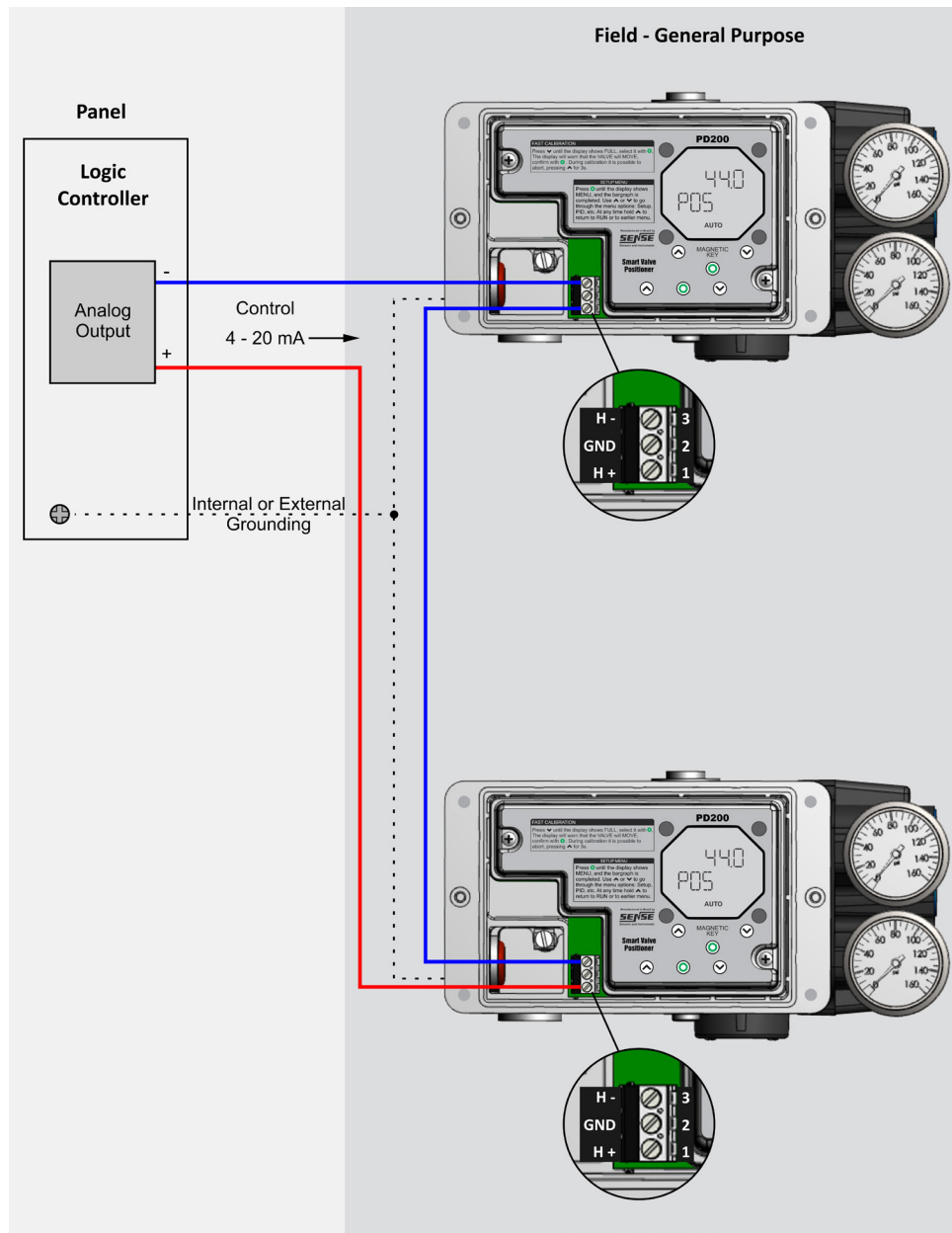

**IMPORTANT**

When using two positioners working in split range and connected to the same analog output, their impedances add up, resulting in 1220 ohms. Therefore, the analog output must withstand a voltage drop of 24.2 Volts.

## 7.4 Alarm Limit Switch Connection

The positioner is supplied with two micro switches that are used as low and high alarm.

### 7.4. Micro Switches

Four terminals are available (two for each micro switch) which can be NO or NC selectable by jumper.

Figure 7-5 Micro Switch Terminal Blocks

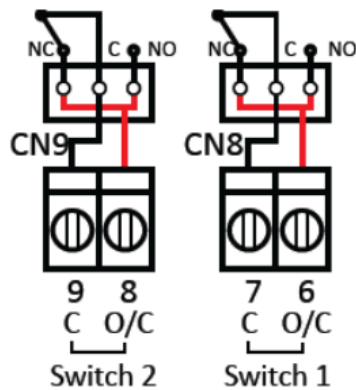

Table 3 Specifications of Micro Switches

Micro Switch Specifications	
Number of outputs	2
Type of output	relay
Type of contact	NO or NC selectable
Switching voltage	125Vac
Max. switching current	2 A

**NOTE:** For installation in potentially explosive atmospheres, refer to Section 9.1 - Entity Parameters

#### Adjustment of Micro Switches

Positioners that are supplied with Alarm Limit Switches must be adjusted by means of cams for actuating the mechanical switches.

#### IMPORTANT

The Alarm Menu can be used as a redundant alarm to the mechanical switches, with the same or different sensing points, but is only intended for indication on the local display. If **UP ALM** or **LOW ALM** alarms appear in the display, it is very important to note that they may not necessarily indicate that the mechanical switches are also actuated at the same points.

See on the next page for details on how to make the mechanical limit switch switching point adjustments.

1 - Remove the main cover by removing the four screws that hold it in the positioner body.

**Figure 7-6 Removing Screws**



2 - Pull the cover with your hand to remove it from the positioner.

**Figure 7-7 Pull the Cover Off**



3 - When removing the main cover, observe the two screws that hold the display and the configuration buttons.

**Figure 7-8 Internal View**



4 - To remove the internal cover with display, remove the two screws that hold the internal cover.

---

**Figure 7-9 Removing Screws**



5 - Pull the cover with display by hand to remove it from the positioner.

---

**Figure 7-10 Pulling off the Internal Cover**



6 - When removing the internal cover, observe the cams and jumpers of the alarms. See the detailed location.

---

**Figure 7-11 View of Jumpers and Cams**



**Figure 7-12 Location of Micro Switches, Cams and Jumpers**

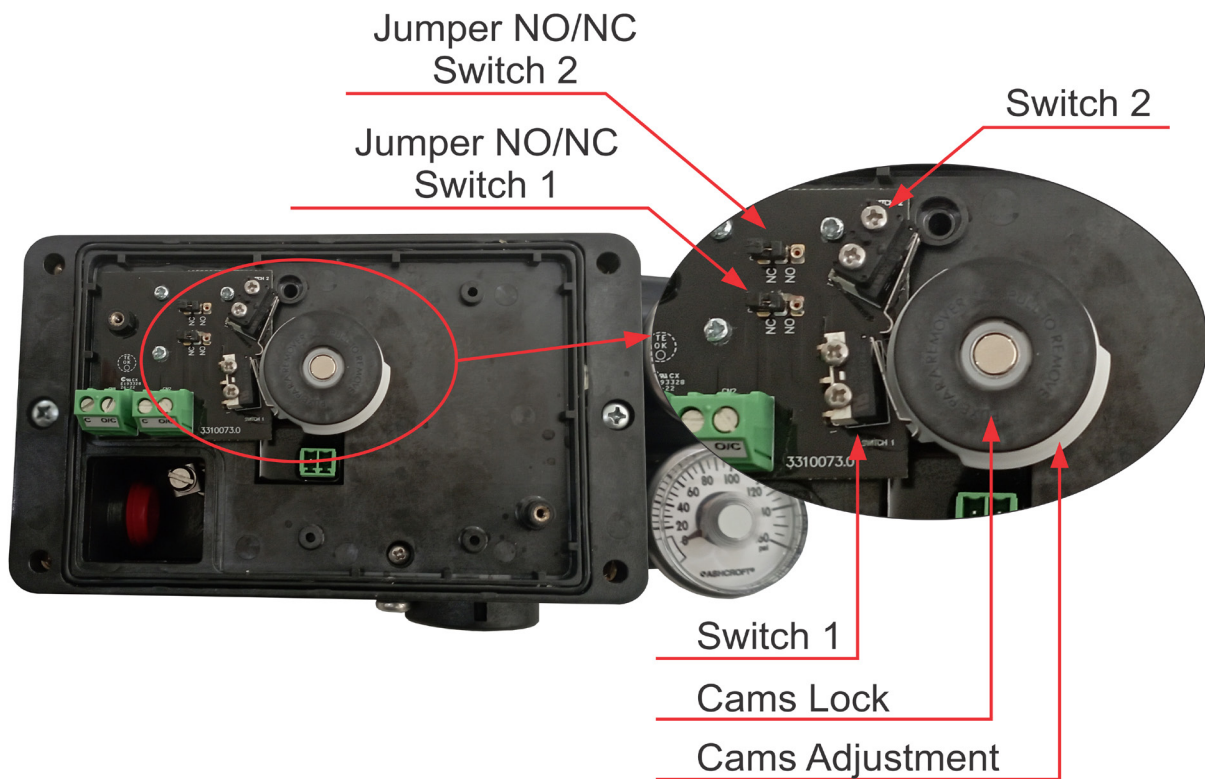

Check the type of contact that will be used and if necessary, change the position of the jumpers. It is possible to use both switches with NO or as NC or one NO and another NC.

**Figure 7-13 Position of the Jumpers**

	<b>Switch 2</b>  NC NO	 NC NO	 NC NO	 NC NO	 NC NO
	<b>Switch 1</b>  NC NO	 NC NO	 NC NO	 NC NO	 NC NO

After automatic calibration, insert a multimeter set to measure resistance at the terminals of micro switch 2 (terminals 8 and 9). If the jumper is in the NO position, with the switch deactivated, the value indicated on the multimeter will be 1 or infinite. When the switch is activated, the multimeter will indicate a resistance value. If the jumper is in the NC position, when the switch is deactivated, the multimeter indicates a resistance value. When activated it indicates 1 or infinity.

**Figure 7-14 NO Jumper**

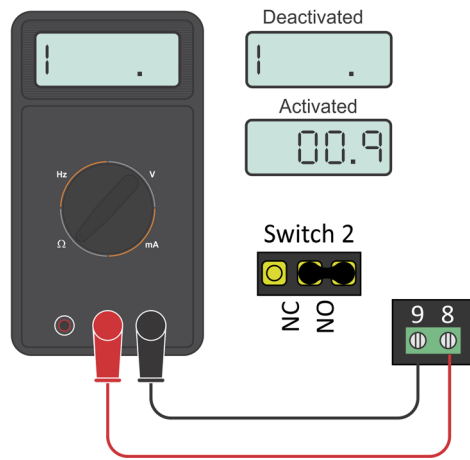

**Figure 7-15 NC Jumper**

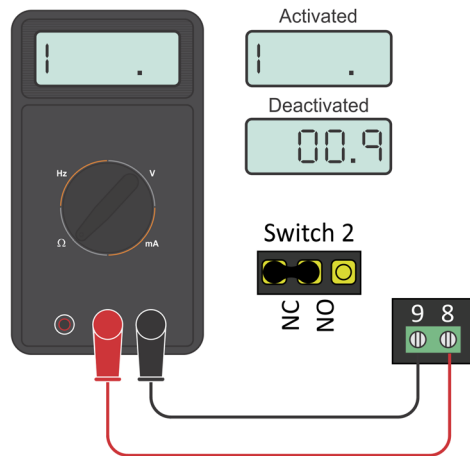

1 - Pull up the cam-lock to remove it and have access to the cam adjustment.

---

**Figure 7-16 Removing the Lock**



2 - Remove the upper cam to access the lower cam setting (switch 2).

---

**Figure 7-17 Removing the Top CAM**

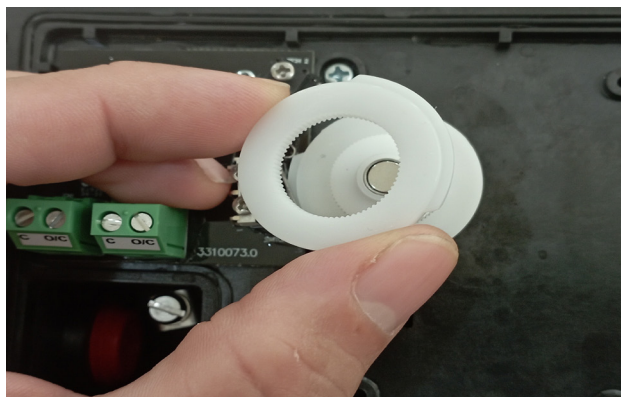

3 - Lift and rotate the lower cam slowly. Check that switch 2 is activating.

---

**Figure 7-18 Adjusting Lower CAM**



4 - After checking the switching point in the desired position, replace the lower cam.

---

**Figure 7-19 Lowering Lower Cam**

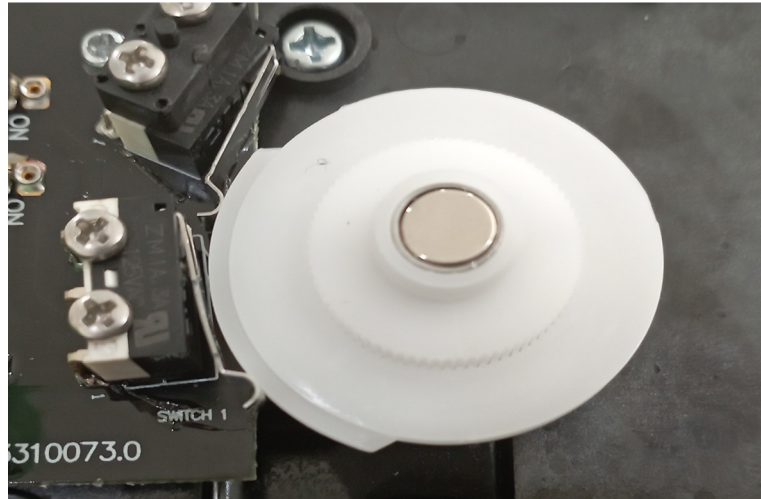

5 - After adjusting the switch point 2, move the valve manually to the position where you want switch 1 to change its state.

6 - Repeat steps 3 and 4 to adjust switch 1, multimeter at the terminals (6 and 7). After checking its switching point, replace the cam and the cam-lock.

---

**Figure 7-20 Securing the Lock**

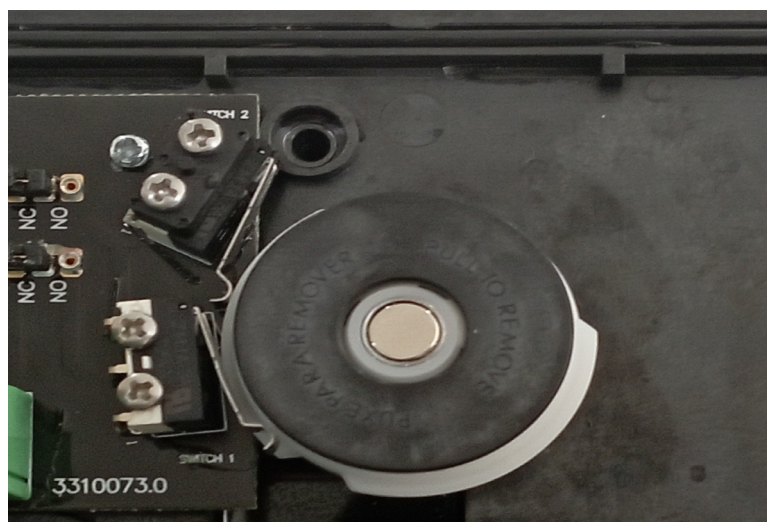

## Section 8: Configuration

### 8.1 Configuration Buttons

The PD200 positioner has 3 mechanical buttons and 3 magnetic buttons for configuration. To configure the positioner by the mechanical buttons it is necessary to open the cover by removing the four screws that hold it to the positioner enclosure.

For configuration using the magnetic buttons, it is not necessary to remove the cover.

Figure 8-1 Positioner with Cover

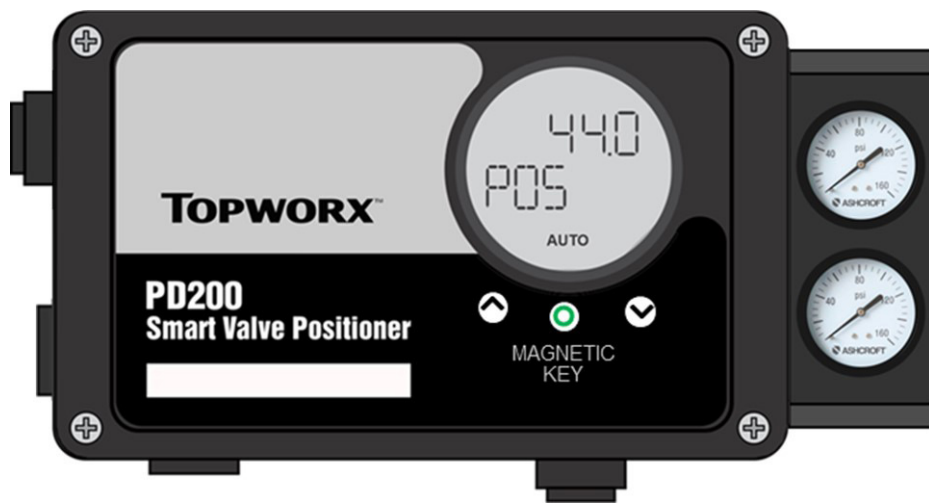

Figure 8-2 Positioner without Cover



## 8.1.1 Magnetic Key

A magnetic key is provided with the positioner to operate the buttons without opening the enclosure.

This key has two sides, one black for the North pole (N) and the other side green for the South pole (S).

To activate the magnetic button, approach the key with the correct pole to the desired button.

**Figure 8-3 Magnetic Key**

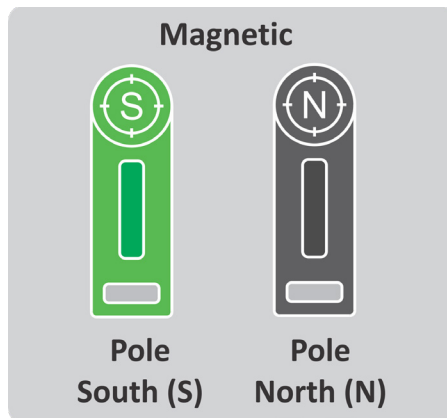

**Figure 8-4 Position of Magnetic Buttons**

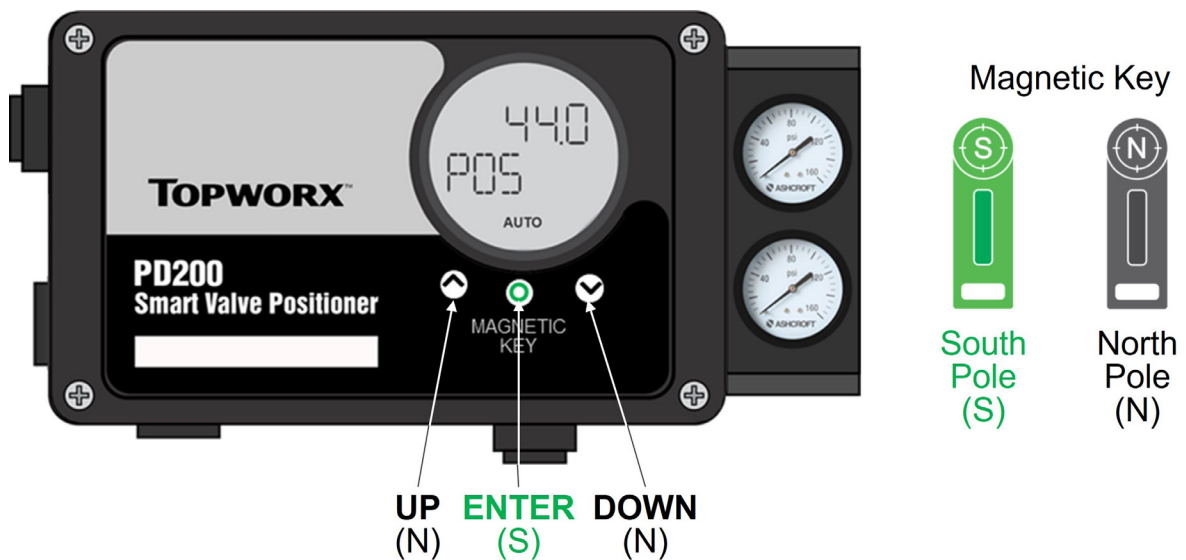

## 8.2 Entering and Navigating the Configuration Menu

To enter and navigate in the configuration menu utilizing the magnetic buttons, it is not necessary to open the cover of the enclosure. To use the mechanical buttons, it is necessary to remove the cover. See below how to enter and navigate in the positioner configuration menu.

Figure 8-5 Position of the Magnetic Buttons

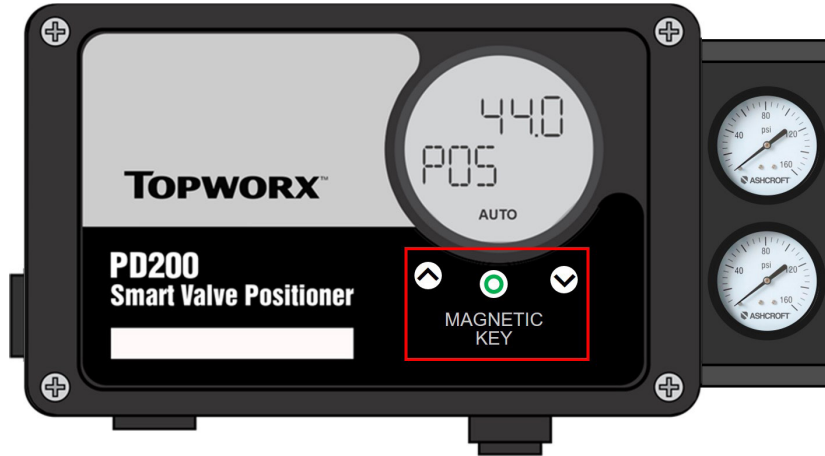
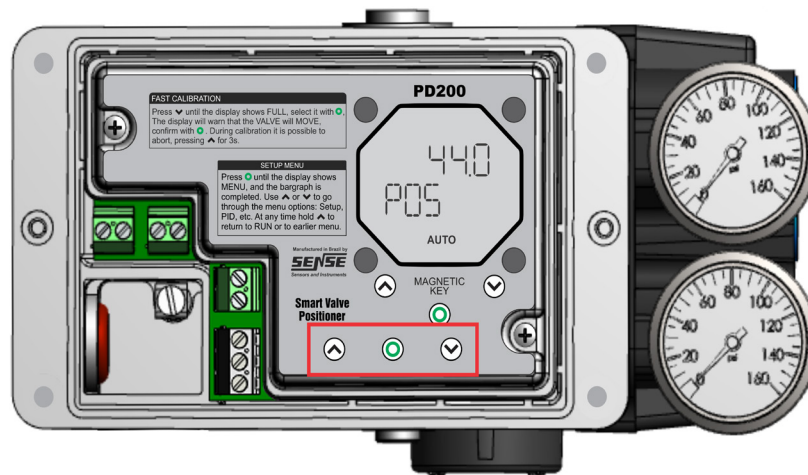
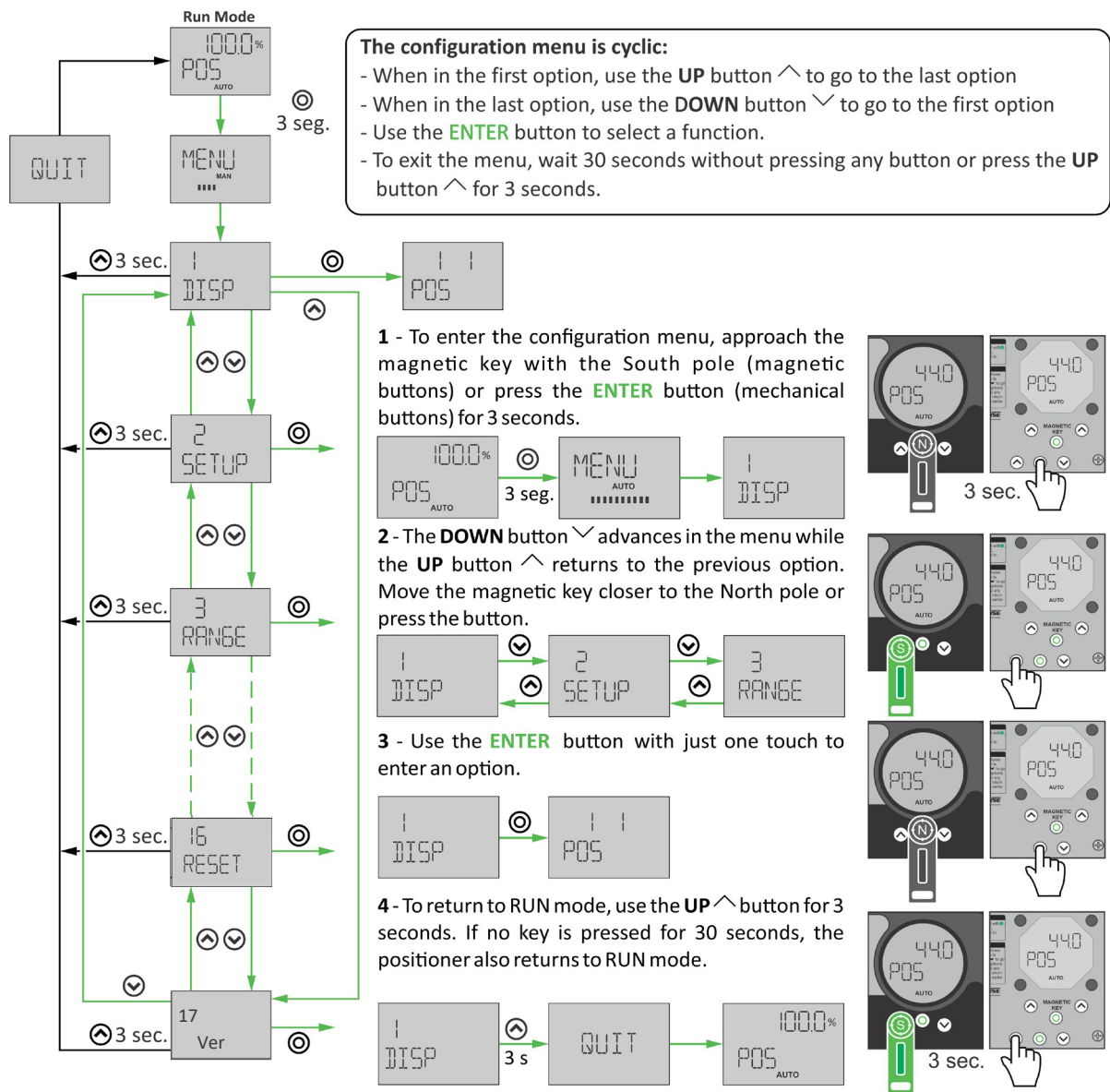

Figure 8-6 Position of Mechanical Buttons



**Figure 8-7 Entering the Menu**



## 8.3 Fast Calibration

When executing fast calibration, the positioner performs the complete calibration, obtaining all the parameters of the valve. For example, the open position, closed position and the PID values.

At any time, it is possible to interrupt the calibration process. Just press (mechanical button) or approach the magnetic key (magnetic button) of the UP key for 3 seconds.

- 1 - Use the DOWN key for 5 seconds.
- 2 - The display will show "FAST PID" then "FULL".
- 3 - Use the ENTER key  $\odot$  and the display will show "Sure SETUP".
- 4 - To execute the calibration process, use the ENTER key  $\odot$ .

**Figure 8-8 Fast Calibration**

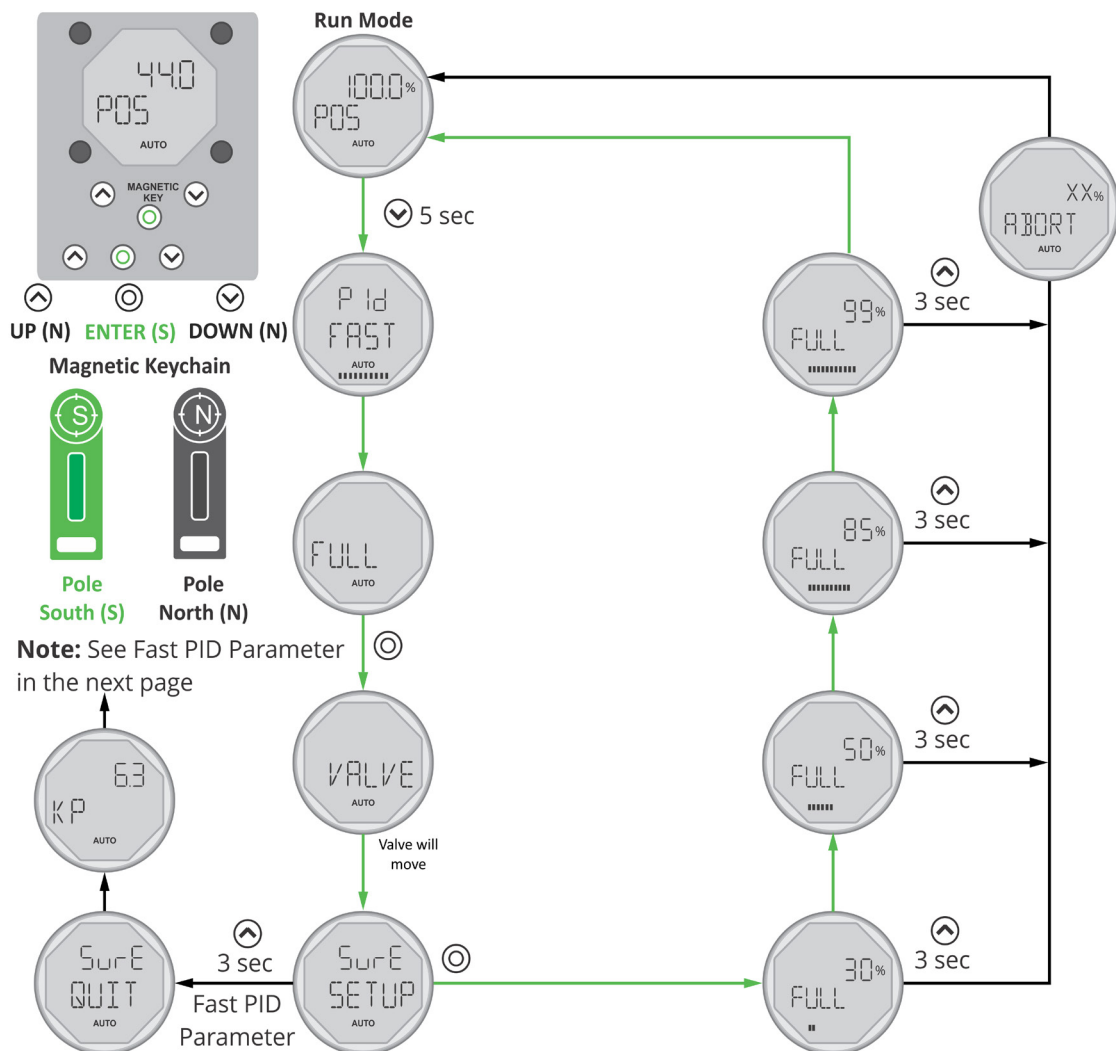

## 8.4 Fast PID

It is possible to access the PID parameters without having to enter and go through the configuration menu. To do this, execute the following procedure:





- 1 - Use the DOWN key for 5 seconds.
- 2 - The display will show "FULL".
- 3 - Use the ENTER key  and the display will show "Sure SETUP". Use the ENTER key  again.
- 4 - To enter the PID parameters, use the UP key for 3 seconds.
- 5 - Use the UP or DOWN keys to select an option.
- 6 - Use the ENTER key  to access the option.
- 7 - Use the UP or DOWN keys to increase or decrease the value. Hold to quickly increase or decrease the value.
- 8 - When the value is ready, store it with the ENTER key  and return to the KP, Td and Tr configuration to select another parameter if necessary.
- 9 - If you enter the KP, Tr or Td option and want to exit, wait 30 seconds without pressing any key or use the UP key for 3 seconds and go back to the PID options.

Figure 8-9 Fast PID



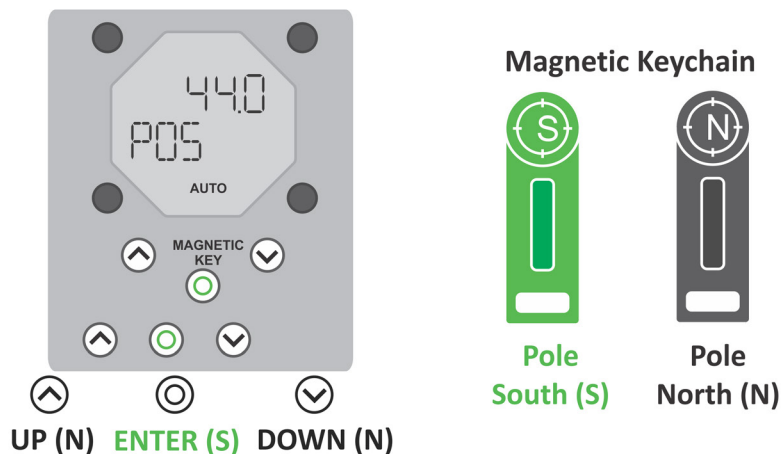
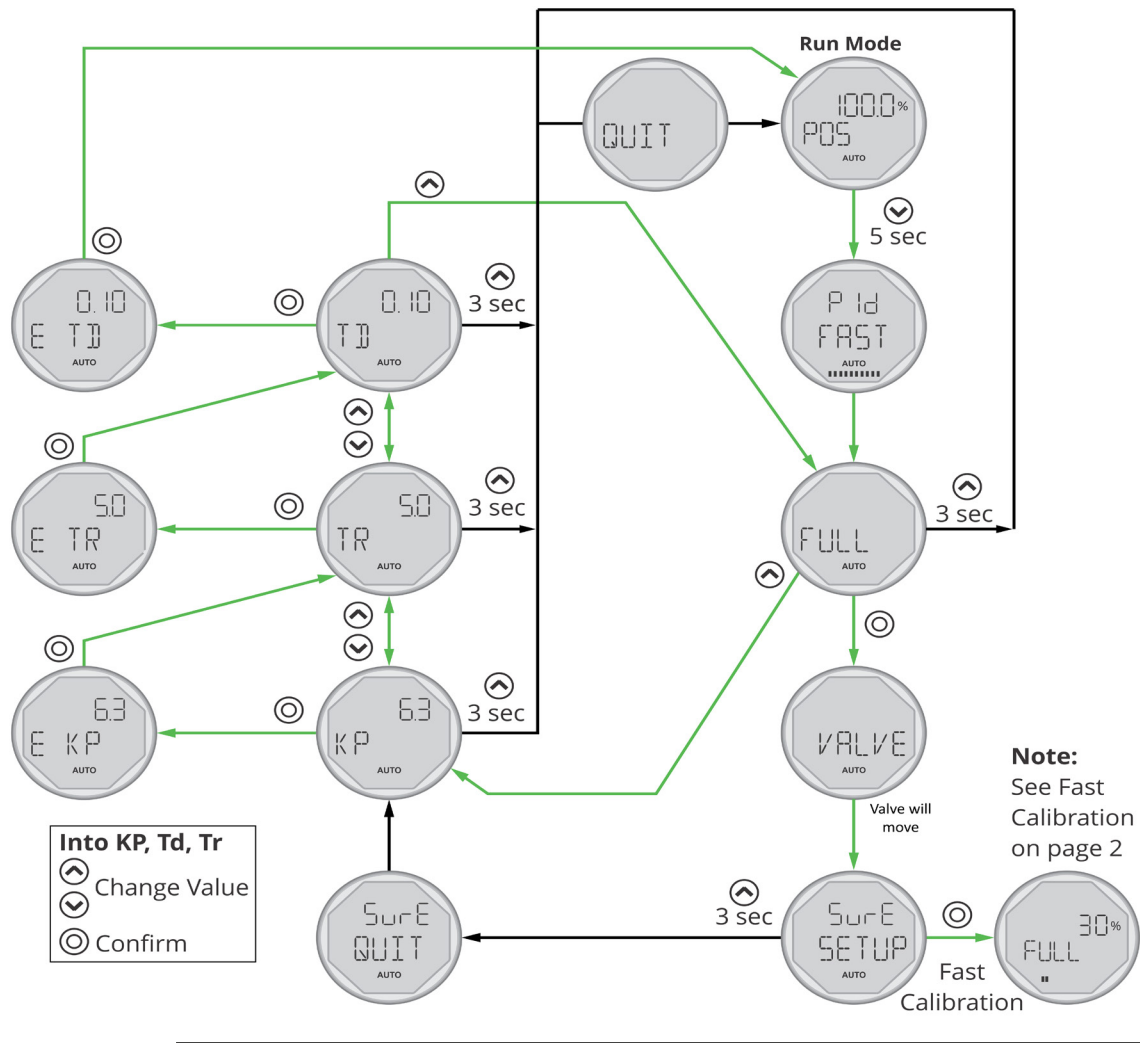

## 8.5 Configuration Menu

The PD200 configuration menu has fifteen functions that can be configured by mechanical or magnetic buttons. When the Menu is accessed, the positioner goes from operation mode (RUN) to configuration mode.

**Figure 8-10 Configuration Menu**



## 8.5.1 Display Menu

**Figure 8-11 Display Menu**

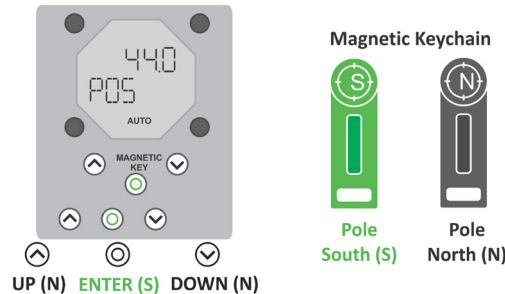

In this function it is possible to select 5 display modes on the LCD display.

**1.1 - POS** (Position): Indicates the current valve position from 0% to 100%.

**1.2 - SP** (Set Point): Indicates the current value of the positioner input signal from 0% to 100%. This parameter represents the value of the desired position. **1.3 - F BACK**

(Feedback): Indicate the current position of the valve in % or the input current in mA. **1.4 - CYCLE:** When selecting this option, the display remains, indicating alternately the current valve position (POS in %) and the current value of the input signal (SP in %).

**1.5 - MV** (Manipulated Variable): Indicates the manipulated variable in % on the display.

MV is informative data for operation diagnosis of the positioner / actuator / valve assembly.

The Manipulated Variable is expressed as the force exerted by the positioner's electro-pneumatic system to keep the control point in equilibrium. It is the result of all forces from the positioner's internal subsystems such as spring, vane nozzle, internal valve plunger and others.

At the end of the positioner production process, adjustments are made to the subsystems so that the MV leaves the factory in the internal setup range of 45% to 55%.

It is recommended that after the positioner has been installed on the actuator / valve assembly, the pneumatic connections have been properly checked, all fasteners and feedback systems have been properly tightened, and a FULL SETUP has been performed, the MV should be observed with the system stably controlling a fixed opening position.

If the positioner/actuator/valve system is well adjusted, the MV is expected to be in the range from 35% to 75%. In case values differ from this range, it is recommended to re-evaluate the system and critically analyze whether the positioner is suitable for the actuator/valve assembly. As an example of inadequacy, actuators that require a large air flow and the 1/4" gauge provided by the PD200 is not able to supply it.

During the periodic maintenance of the system, it is recommended to recheck the MV, in the same stability condition used in the initial installation.

If the MV indicates a value well below the initial value, it indicates some anomaly in the positioner or in the actuator / valve assembly, which may include loosening of the counterbalance spring, or deregulation of the internal pressure regulator.

On the other hand, if the MV has increased, this may be a sign of valve or actuator stalling, which is requiring more force from the positioner to keep the same condition.

Note that it is normal during the control phase of the positioner that the MV changes by excursion throughout the range, indicating that the positioner is varying the applied force for control to be exercised.

In other words, the MV comes to contribute to the diagnosis of the control system, which is subject to performance variations due to process conditions and wear of moving parts.

**Figure 8-12 Display Indication Options**

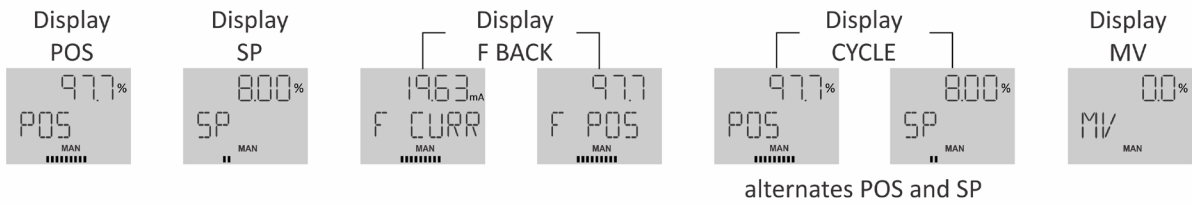

**Figure 8-13 Menu Display**

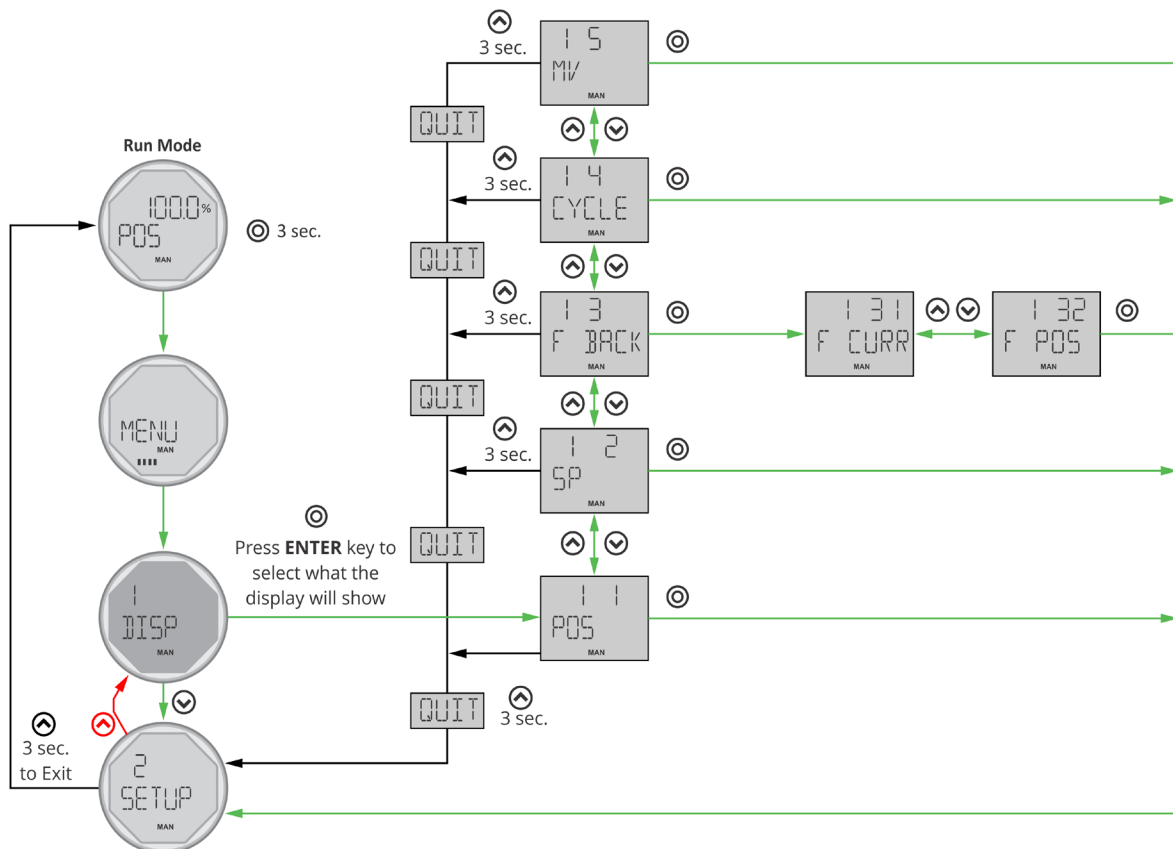

### Accessing the Display Menu

- Press the ENTER key  $\circ$  for 3 seconds to access the menu.
- Use the ENTER  $\circ$  key to select what the display will show.
- Use the UP or DOWN arrows to navigate to the item you wish to set.
- Use the ENTER  $\circ$  key to set the option.

### Conversion of mA to %

To indicate the valve position in %, the microprocessor makes a calculation which is illustrated below:

For the example, points of the scale from 0 to 100%.

**Figure 8-14 Conversion from mA to %**

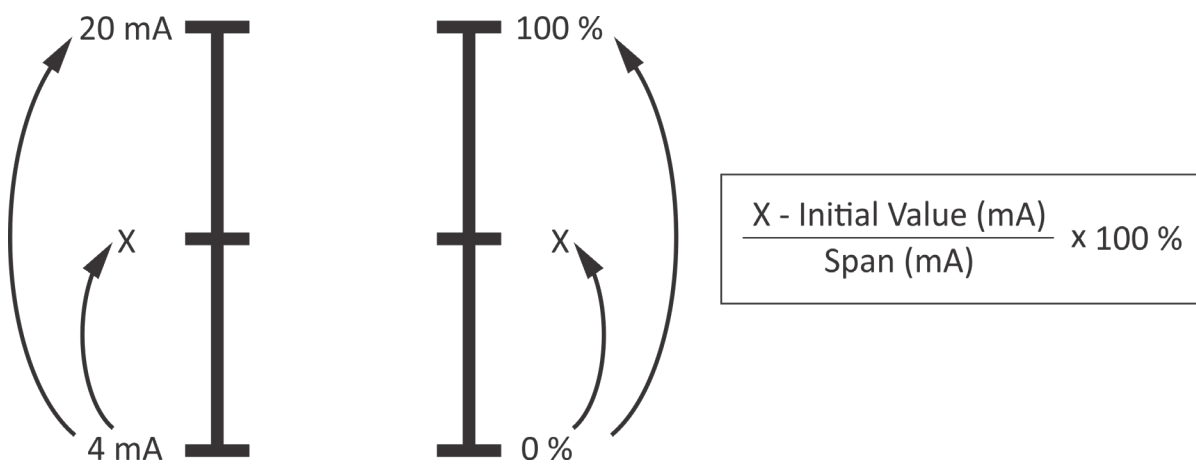

#### 1° Point X = 8 mA

Using the equation of the Figure 8-14: Conversion from mA to %, we have:

**Replacing the X with 8 mA:**

$$\frac{X - \text{Initial Value (mA)}}{\text{Span (mA)}} \times 100 \% \longrightarrow \frac{8 - 4}{16} \times 100 \% = 25 \%$$

#### 2° Point: X = 12 mA

Using the equation of the Figure 8-14, we have:

**Replacing the X with 12 mA:**

$$\frac{X - \text{Initial Value (mA)}}{\text{Span (mA)}} \times 100 \% \longrightarrow \frac{12 - 4}{16} \times 100 \% = 50 \%$$

**3° Point: X = 16 mA**

Using the equation of the Figure 8-14, we have:

$$\frac{X - \text{Initial Value (mA)}}{\text{Span (mA)}} \times 100 \% \longrightarrow \frac{16 - 4}{16} \times 100 \% = 75 \%$$

**Replacing the X with 16 mA:**

**4° Point: X = 20 mA**

Using the equation of the Figure 8-14, we have:

$$\frac{X - \text{Initial Value (mA)}}{\text{Span (mA)}} \times 100 \% \longrightarrow \frac{20 - 4}{16} \times 100 \% = 100 \%$$

**Replacing the X with 20 mA:**

## 8.5.2 Setup Menu

In this function, it is possible to perform the 3 calibration modes of the positioner:

**2.1 - FULL:** Recognizes the open and closed points and adjusts the best parameters for the PID.

Note: Recommended to complete for the first calibration.

**2.2 - AUTO:** Learn the open and closed points (0% and 100%).

Note: Recommended use in a process change or after maintenance.

**2.3 - TUNE:** Automatically calculates PID parameters (Kp, Tr and Td).

Note: Recommended use in a process change.

**Figure 8-15 Menu Setup**

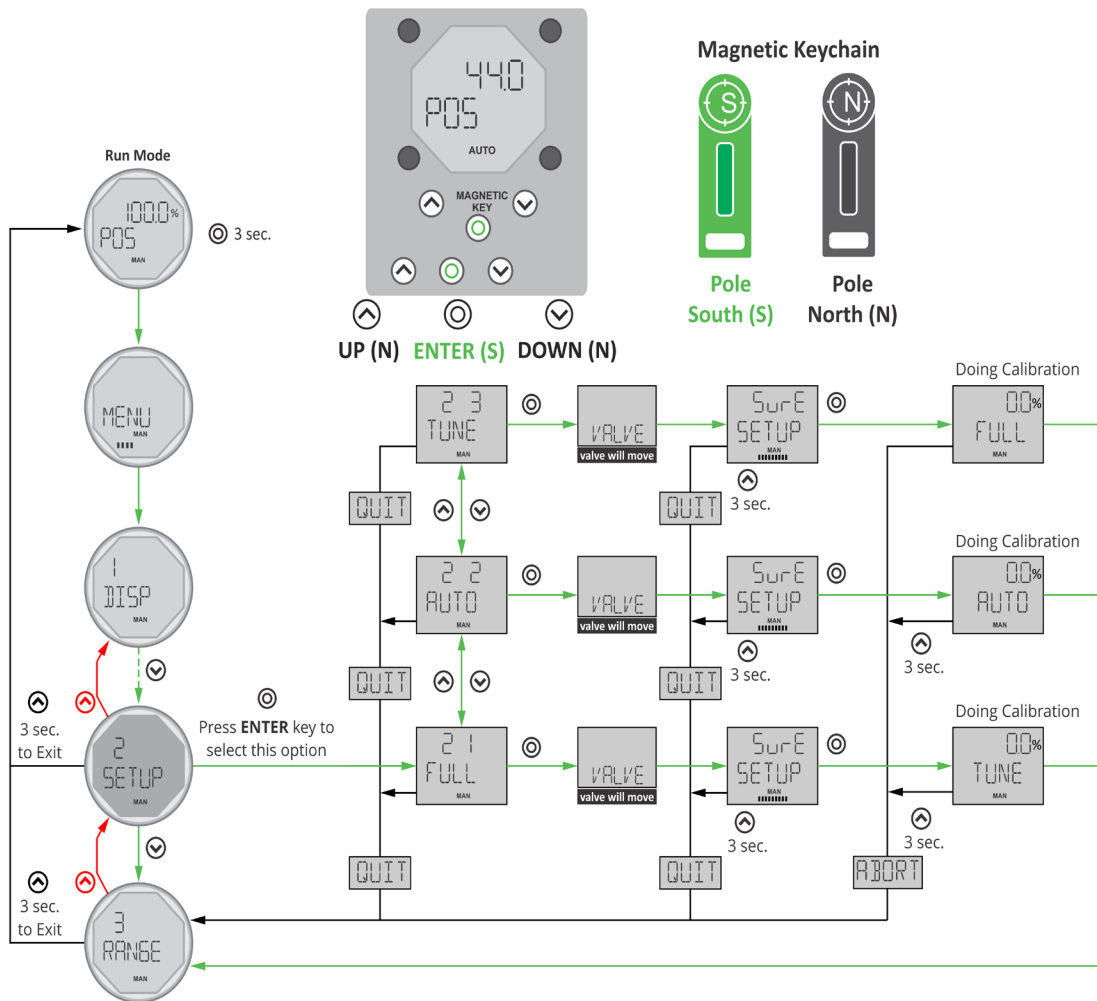

**Entering the Setup Menu**

- Press the ENTER key  $\circ$  for 3 seconds to access the menu.
- Use the DOWN key to go to the SETUP options. The UP key returns to the previous option.
- Use the ENTER key  $\circ$  to select this function.
- Use the UP or DOWN keys to navigate to the item to be set.
- Use the ENTER  $\circ$  key on the calibration procedure to be carried out.
- To resume the selected calibration process, confirm with the ENTER  $\circ$  key.
- To exit without calibrating, use the UP key for 3 seconds.

**NOTE:** It is possible to quit the calibration process at any time; to do that, use the UP key for 3 seconds. The ABORT message will appear on the display.

**IMPORTANT**

When performing any maintenance on the valve or positioner, you must redo the auto calibration, where the positioner learns the open and close points, in order to eliminate any valve positioning error.

## 8.5.3 Range Menu

Range, measuring range or working range is a set of values of the measured variable that are comprised between the minimum and maximum values of the measuring, transmission, or control capability of the instrument. It is expressed by setting its extreme values, for example 0 to 100 mm, but this scale can be configured.

**3-1 - ZERO:** It is always the starting point of the measuring scale. This parameter allows adjusting the ZERO point from 0 to 20% of the total travel of the valve.

**Figure 8-16 Example of Range**

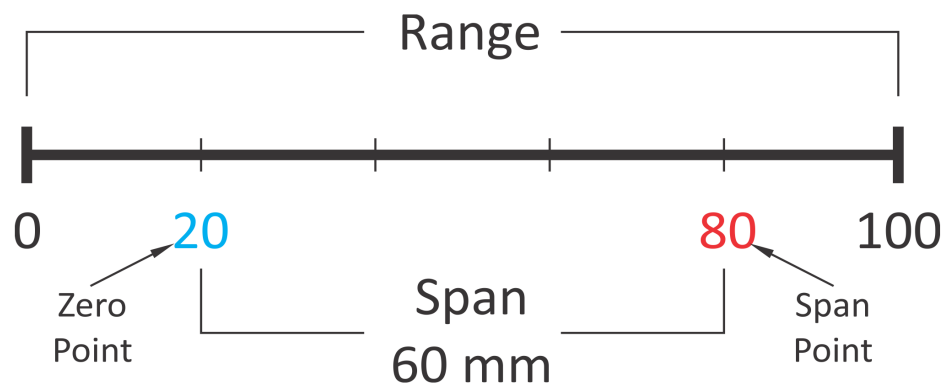

**3-2 - SPAN:** This parameter allows adjusting the end point of the measuring scale from **80 to 100%** of the valve stroke.

Consider if a valve has a stroke of 0 to 100 mm (SPAN = 100mm), but our application requires that the valve has a stroke of 20 to 80 mm (SPAN = 60 mm). We then set the ZERO point at 20% and SPAN at 80%. See Figure 8-16: Example of Range

Range 0 to 100 mm (0 to 100%)

ZERO point set to 20% (in the example 20 mm)

SPAN point set to 80% (in the 80 mm example)

SPAN: 80 mm - 20 mm = 60 mm

**Figure 8-17 Range Menu**

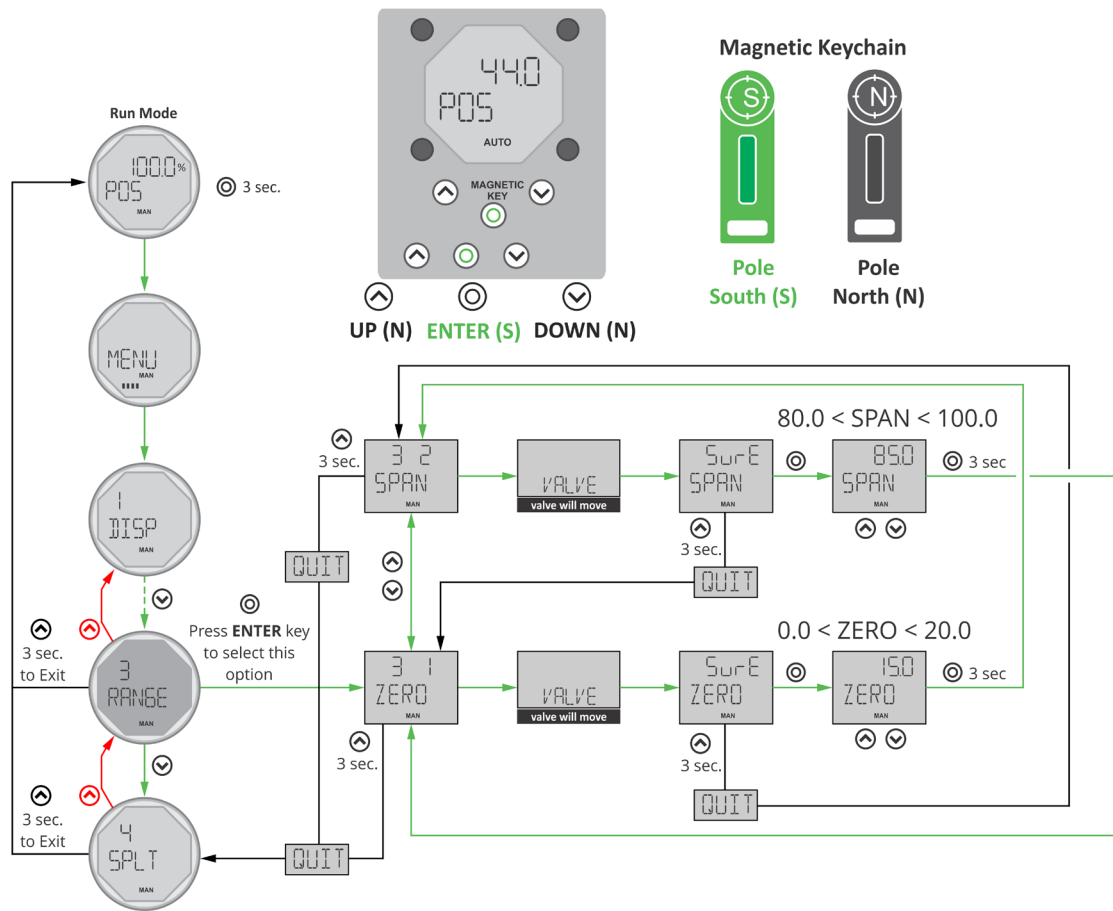

**Entering the Range Menu**

- Press the ENTER key  $\circ$  for 3 seconds to access the menu.
- Use the DOWN key to go to the RANGE option. The UP key returns to the previous option.
- Press the ENTER key  $\circ$  to select this function.
- Use the UP or DOWN keys to navigate to the item you want to set.
- Use the ENTER  $\circ$  key to select the option.
- Use the ENTER  $\circ$  key to select the digit and the UP or DOWN keys to increase or decrease the value. Hold to quickly increase or decrease the value.
- When the value is ready, store it with the ENTER key  $\circ$  3 seconds and return to the ZERO / SPAN menu to set the other one if desired.
- If you want to exit the ZERO / SPAN menu, press the UP key for 3 seconds and return to the main menu.

## 8.5.4 Menu Split Range

Split range control is a system in which there is only one control signal and more than one valve to be controlled.

In the example below, it will assume that the output of the controller is sent to two valves.

The splitter defines how each valve is actuated as the controller's output changes from 0 to 100%. In most split range applications, the controller adjusts the opening of one of the valves when its output is within the range 0 to 50% and the other valve when its output is within the range 50% to 100%. In the example, the PV-002 valve will close in response to increasing pressure in TQ-001, while the PV-001 valve will open when the pressure increases beyond the adjusted point.

**Figure 8-18 Split Range Control**

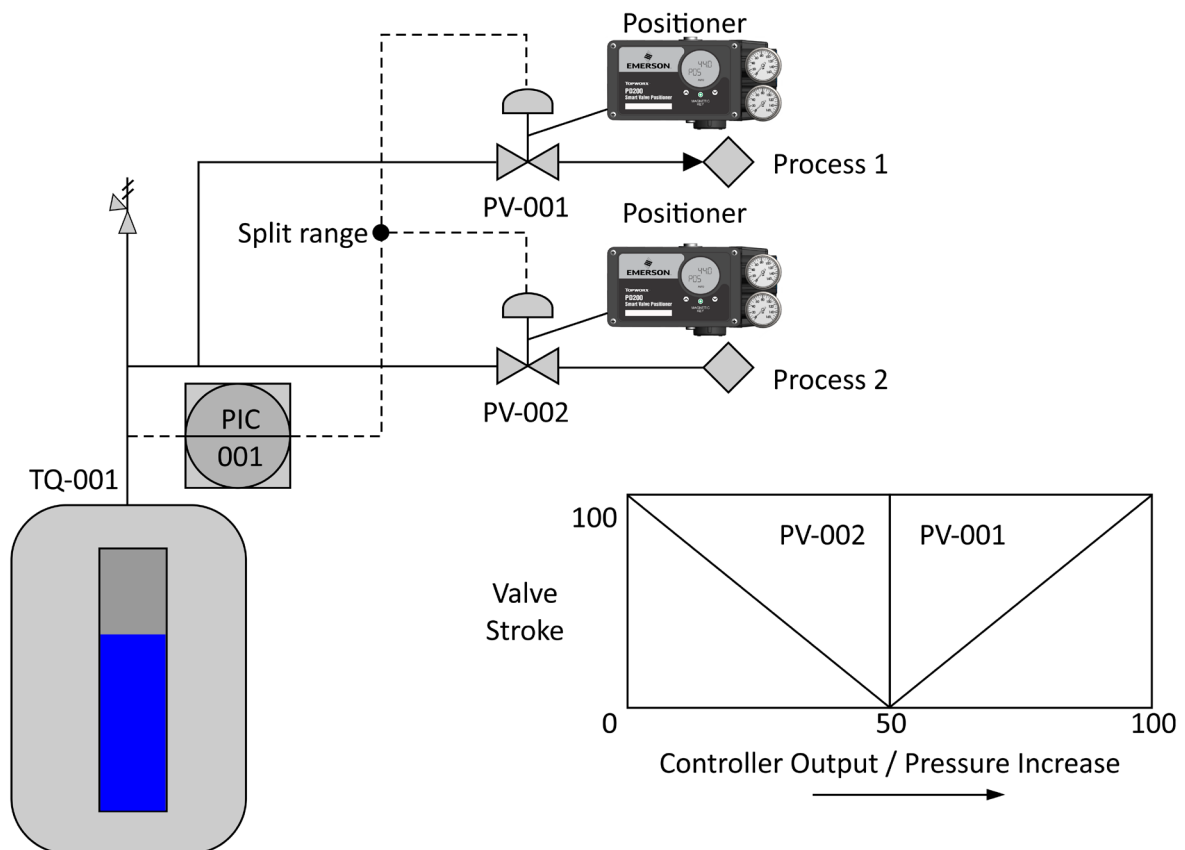

When the pressure increases beyond the setpoint in the range of 0% to 50% of the controller output, the PV-002 valve must go from fully open to fully closed. When the pressure increases beyond the set point in the range of 50% to 100% of the controller output, the PV-001 valve must go from fully closed to fully open.

**Figure 8-19 PD200 in Split Range**

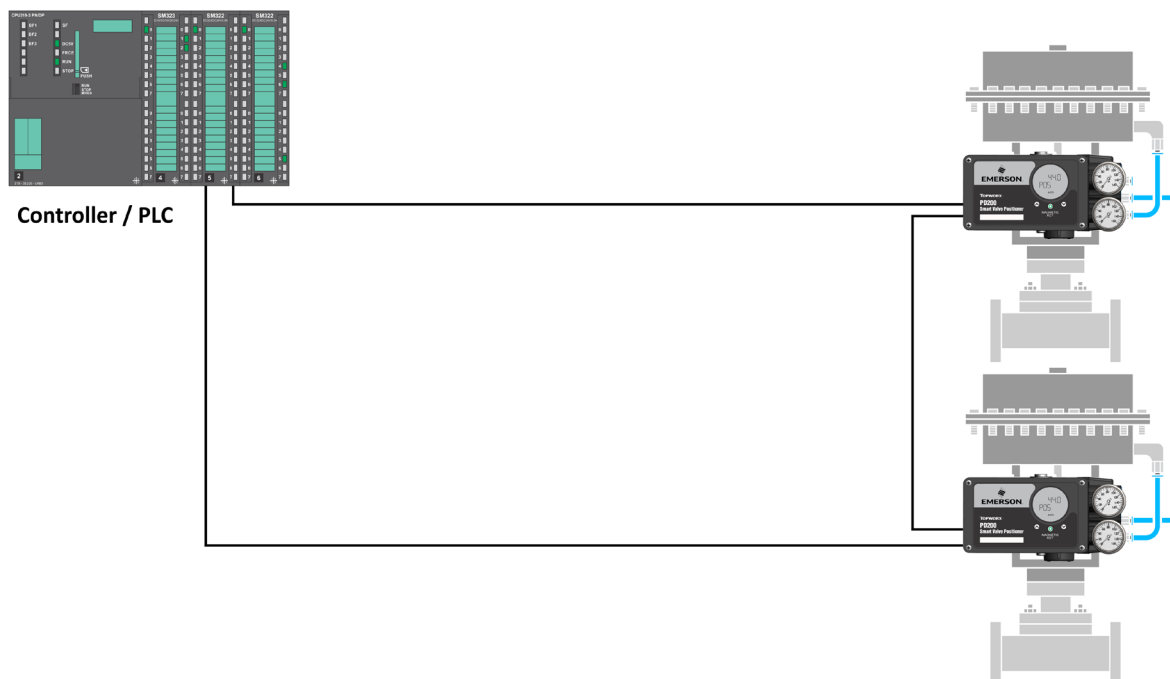

In this function, it is possible to adjust the positioner to operate from 4 to 12 mA or 12 to 20 mA.

**4.1 - (4 ... 12mA):** Split Range enabled from 4 to 12mA.

**4.2 - (12 ... 20mA):** Split Range enabled from 12 to 20mA.

**4.3 - (DESAB):** Split Range disabled.

Figure 8-20 SPLT Menu

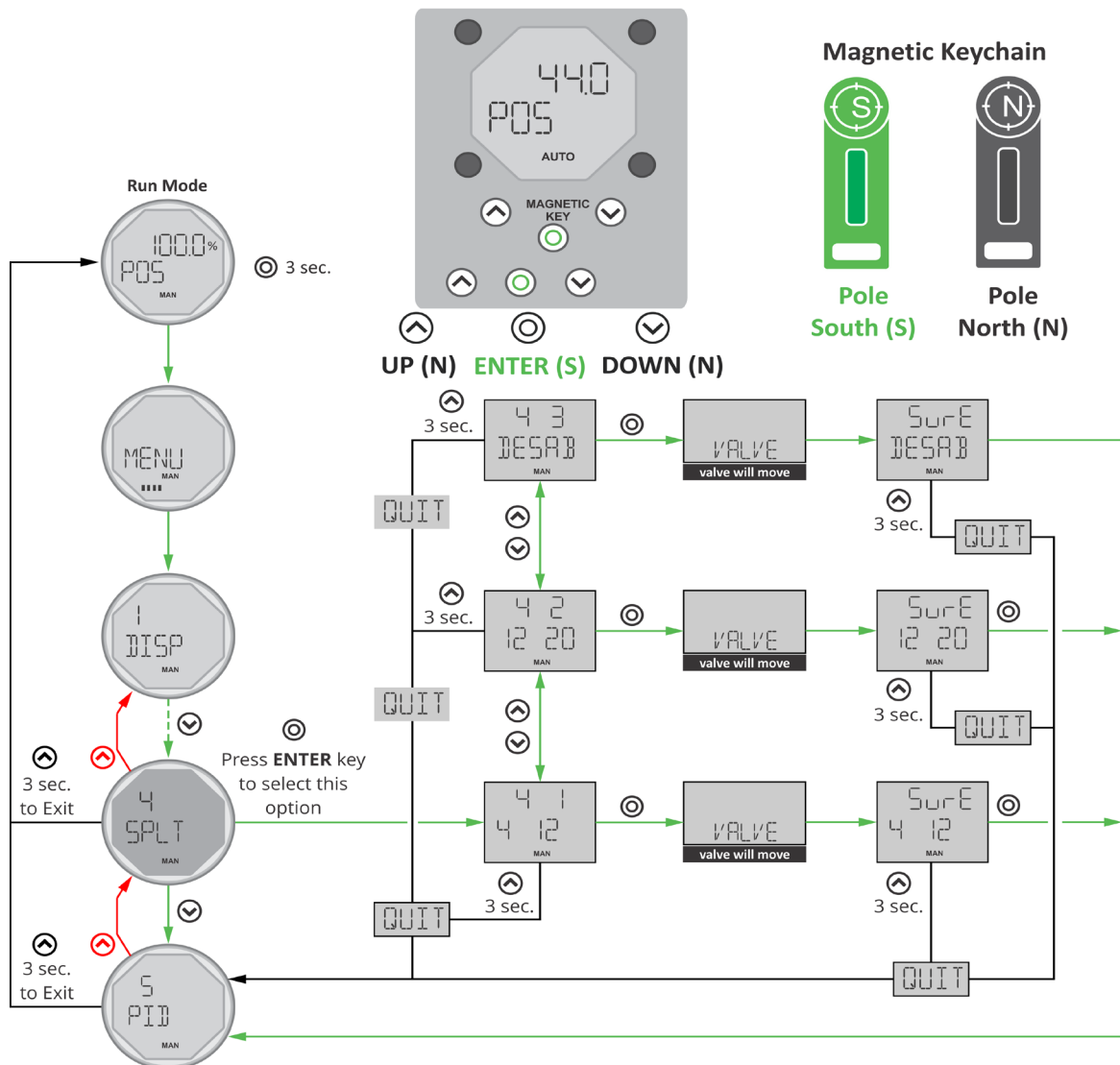

### Accessing the SPLT Menu

- Press ENTER ○ for 3 seconds to access the menu.
- Use the DOWN key to go to the SPLT option. The UP key returns to the previous option.
- Use the UP or DOWN arrow keys to select an option.
- Use the ENTER ○ key to select the option.
- To proceed with the desired option, confirm with the ENTER key ○.
- To exit the selected option, use the UP key for 3 seconds.

## 8.5.5 PID Menu

Proportional, integral and derivative control (PID control or simply PID) is a process control technique. It unites proportional, integral and derivative actions so that an error signal is minimized by the proportional action, zeroed by the integral action and obtained with an anticipative speed by the derivative action. PID control is the most widely used in industrial automation and can act in four ways:

- Proportional control (P)
- Proportional and integral control (PI)
- Proportional and derivative control (PD)
- Proportional Integral and Derivative control (PID)

### Proportional Control

- Proportional control always works on top of the system error, that is, it will generate an output according to the error and not as a function of time.
- The gain ( $K_p$ ) is the variable that the proportional controller uses for control. A value that is too low for  $K_p$  will result in slow control, while a value that is too high will result in the system oscillating around the setpoint.
- As can be seen from the adjacent graph, the proportional action does not eliminate the error, which is called offset.
- This residual error consists of the steady state and can be changed by adjusting the gain ( $K_p$ ).

---

**Figure 8-21 Proportional Control Chart**

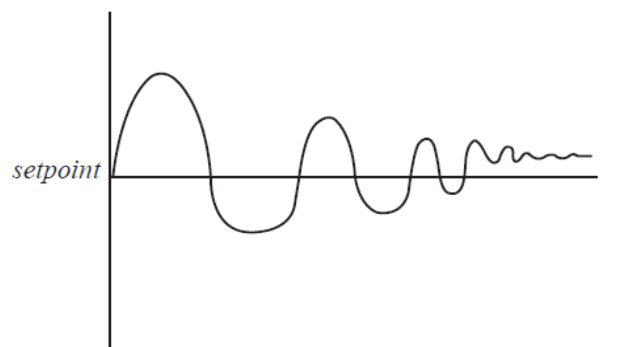

### Integral Control

- In integral action, the correction speed is proportional to the error, that is, in integral action the control variable is time ( $T_r$ ).
  - Because this action provides a relatively slow correction speed when used alone, in practice, it is always accompanied by proportional action (PI control).
  - The PI control eliminates the offset that the proportional control presents, and it has a faster response than the integral alone.
  - A too small value of  $T_r$  will lead to large oscillations that will take longer to stabilize.
  - A too high value of  $T_r$  will result in a very slow and inefficient integration.
-

**Figure 8-22 PI Control Chart**

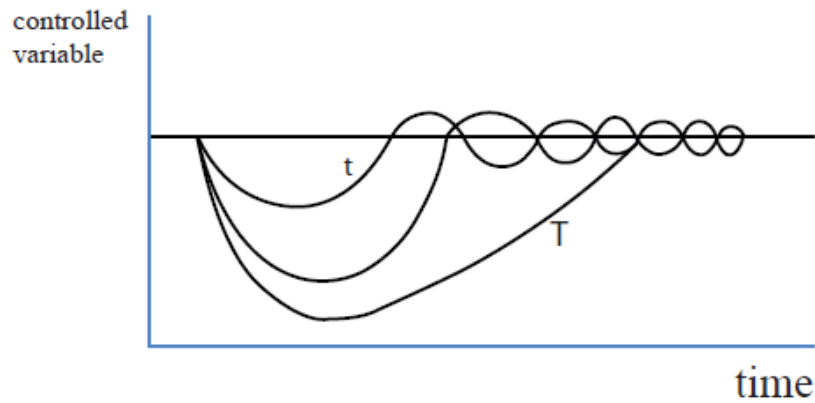

**Derivative Control**

The derivative action like the integral action works with time ( $T_d$ ) and is also used in conjunction with the proportional action (PD control).

This control is very efficient with respect to correction because it starts the correction immediately as soon as the error starts (as the derivation of constant is always zero).

As in PI control this control also suffers effects for very high or very low values for time ( $T_d$ ).

When we have large times, we will have more stability in the system with low-speed response.

And when the time is small, there are many oscillations and falls in the stability of the loop.

The PD control has the same peculiarity of proportional control only, which is to leave a residue that is called offset, even though the derivative action improves the stability of the system.

Graphically the PD control is like PI control differing only by leaving an offset.

**Figure 8-23**

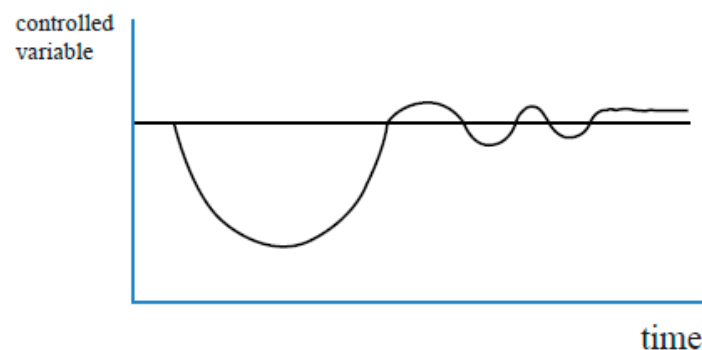

### PID Control

- PID control uses proportional, integral, and derivative actions together.
- As it joins all the control actions it makes the error correction faster and more assertive by eliminating the offset left by the proportional and derivative actions.  
See the actions in graphical form in the picture below.

**Figure 8-24 PID Control Chart**

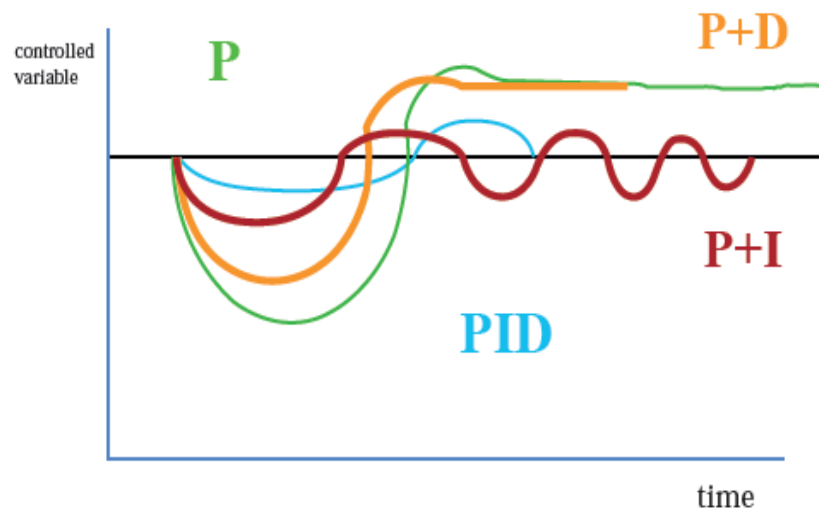

### PID Tuning Methods

The positioner automatically adjusts the PID parameters in the calibration process, but you can change the values for proportional gain ( $K_p$ ), integral time ( $T_r$ ) and derivative time ( $T_d$ ) manually. To this end, there are a few methods for adjusting the parameters (tuning).

#### Limit Sensitivity Method

This method will work on the closed loop setting. It will first reduce the effect of the integral and derivative actions to a minimum. Only then will it start with the gain ( $K_p$ ) and increase it until the controlled variable oscillates with the amplitude that is constant making small perturbations in the system. The most common adjustment is the one that reaches a quarter of the previous amplitude. This method can be used in many processes.

#### Reaction Curve Method

This method is widely used in first order systems since it is less complex. It will present a S-shaped curve through the two constants delay ( $L$ ) and time ( $T$ ), through the  $K$ -coordinate.

#### Attempted and Error Method

This is one of the most used methods because it is simple. It consists in modifying the control actions and observing the effects on the process (as the name suggests).

However, to be able to work with this system, it is important to have knowledge of both the process and its algorithm.

It cannot be used for open loops because it can generate instability when the gains are too low or too high.

Another disadvantage that can occur with this method is that depending on the amount of adjustment, it will take a lot of time to tune. Depending on the conditions, this could impair the process.

### **Ziegler and Nichols Method**

Ziegler and Nichols suggested a process tuning rule to get a given performance specification, such a method took their names. It is suitable for complex plants in which the mathematical modulus is not easily obtained, or when the plant model is unknown.

A few rules for PID tuning are presented. These rules are based on his experiments which works on steps and gain. They provide an estimate of the parameters of integral time, derivative time, and proportional gain. Sometimes this signal can generate a very large step response. In that case you will need to do some finer tuning to get the desired adjustment.

### **Auto Tuning Method**

This method is an improvement of the Ziegler and Nichols method. The proportional gain, derivation, and integration variables are calculated automatically. The data for the calculations is usually obtained from the reaction curve, causing a step-shaped disturbance.

---

### **IMPORTANT**

The PD200 firmware is the result of years of experience in controller tuning and, in conjunction with the auto-calibration routines, provides a very close to optimal set of parameters, but the product also allows the instrumentalist to make a final adjustment of the parameters ( $K_p$ ,  $T_r$  and  $T_d$ ), which can add from experience of the valve / actuator and the controlled process.

---

### **IMPORTANT**

The intention of describing PID control in this manual is only for a basic notion of control, if you want to know more about it, please look for specific literature on process control.

---

**5.1 -  $K_P$ :** Allows you to adjust the proportional gain of the PID control with values between **0 to 50**.

**5.2 -  $T_R$ :** Allows you to adjust the integral time of PID control with values between **0.1 to 50 (s)**.

**5.3 -  $T_D$ :** Allows you to adjust the derivative time of PID control with values between **0 to 10 (s)**.

Figure 8-25 PID Menu

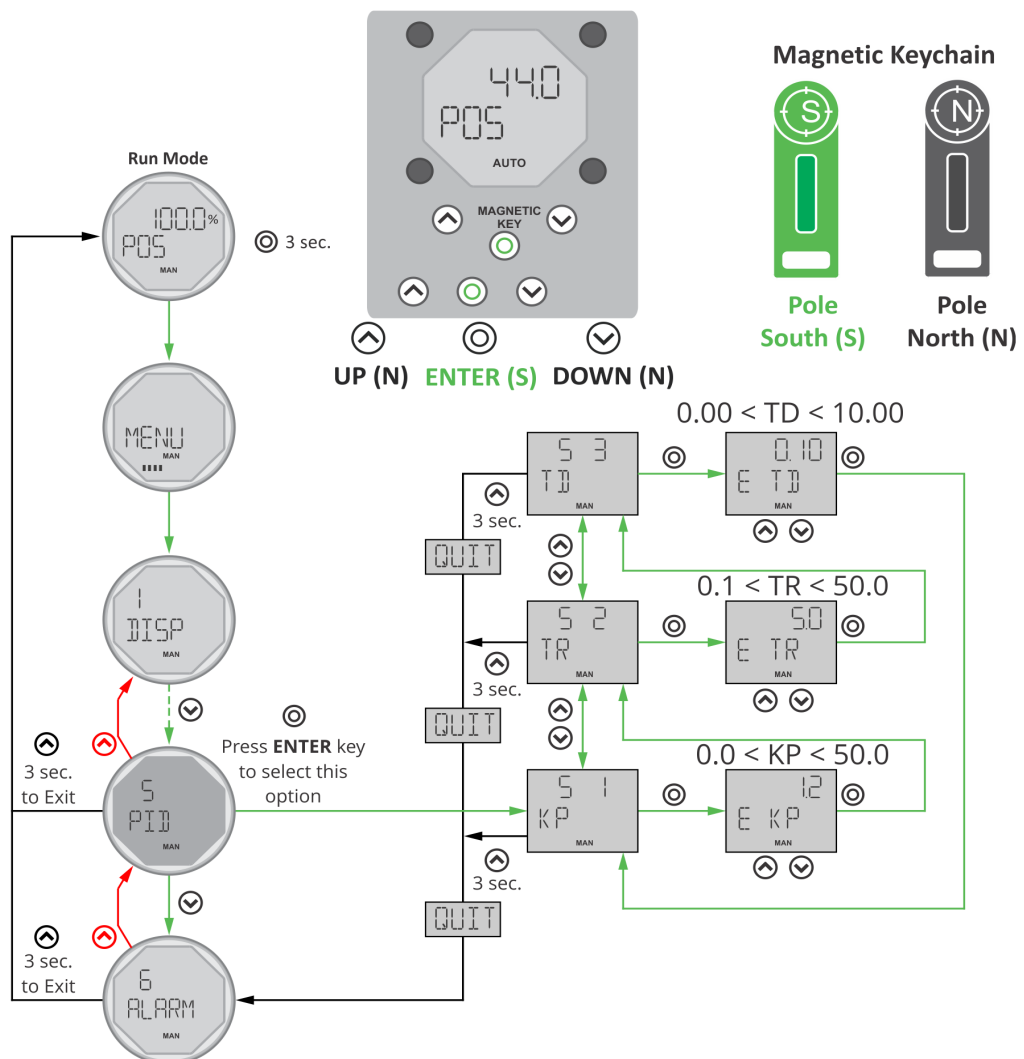

### Accessing the PID Menu

- Press ENTER  $\circ$  for 3 seconds to enter the menu.
- Use the DOWN key to move to the PID option. The UP-key returns to the previous option.
- Press ENTER  $\circ$  to select the option.
- Use the UP or DOWN keys to select an option.
- Press ENTER  $\circ$  to select the option.
- Use the UP or DOWN keys to increase or decrease the value. Hold down to increase or decrease rapidly.
- When the value is ready, store it with the ENTER  $\circ$  key and return to the KP, Td, and Tr setting to set the other if desired.
- If you enter KP, Tr, or Td and want to exit, wait 30 seconds without pressing any keys and return to the PID options.
- If you want to exit the PID menu, use the UP key for 3 sec and return to the main menu.

**⚠ WARNING**

If you change any value, it will be implemented immediately, which can cause process instability and lead to incorrect valve positioning.

**IMPORTANT**

If the user changes the PID control parameters incorrectly and does not remember the previously calculated values, simply perform the TUNE procedure again.

## 8.5.6 Alarm Menu

Alarm Menu will only provide the visual alarm on the display, as indicated in the figure below:

**Figure 8-26 Example Alarm Indication**

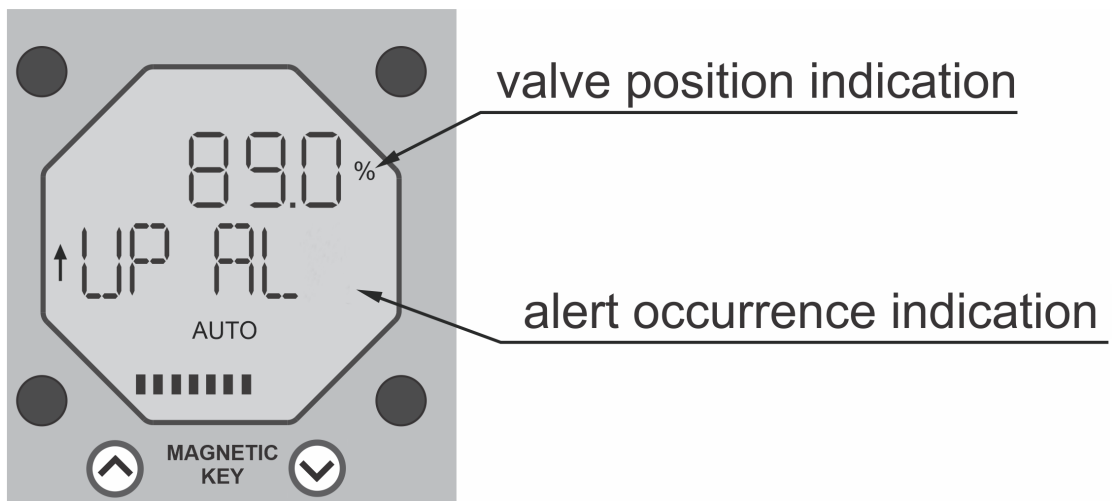
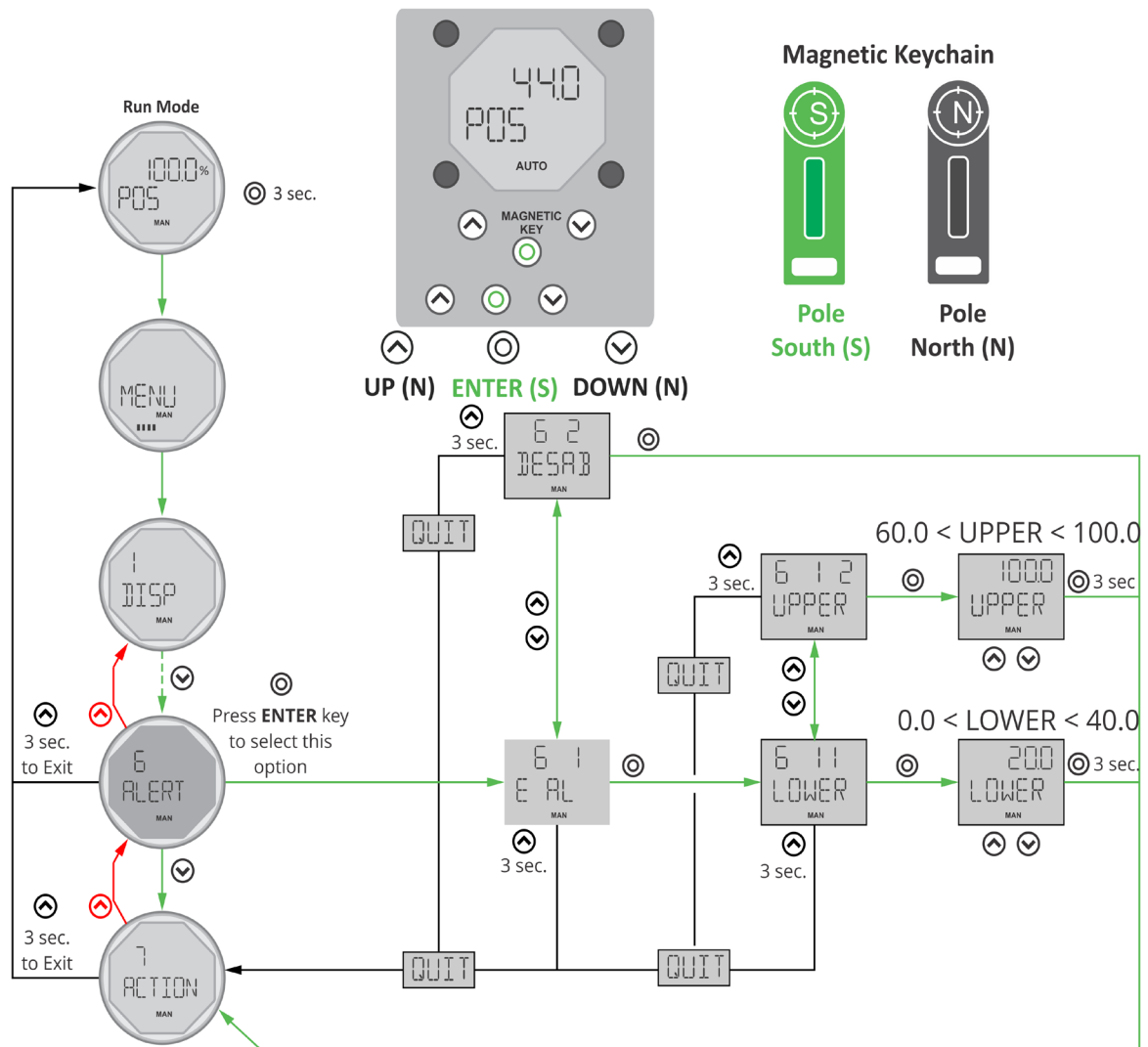

Figure 8-27 Alarm Menu



- 6.1 - E ALM:** Enables the positioner alarm
- 6.1.1 - LOWER**
- 6.1.2 - UPPER**
- 6.2 - DESAB:** Disables the alarm.

## 8.5.7 Action Menu

This function relates the control signal to the valve positioning:

**7.1 - DIRECT:** Direct Action: 4mA valve closed signal (0%). 20 mA signal, valve open (100%).

**7.2 - REVERS:** Reverse Action: 4mA signal, valve open (100%). 20 mA signal, valve closed (0%).

**Figure 8-28 Direct and Reverse Action**

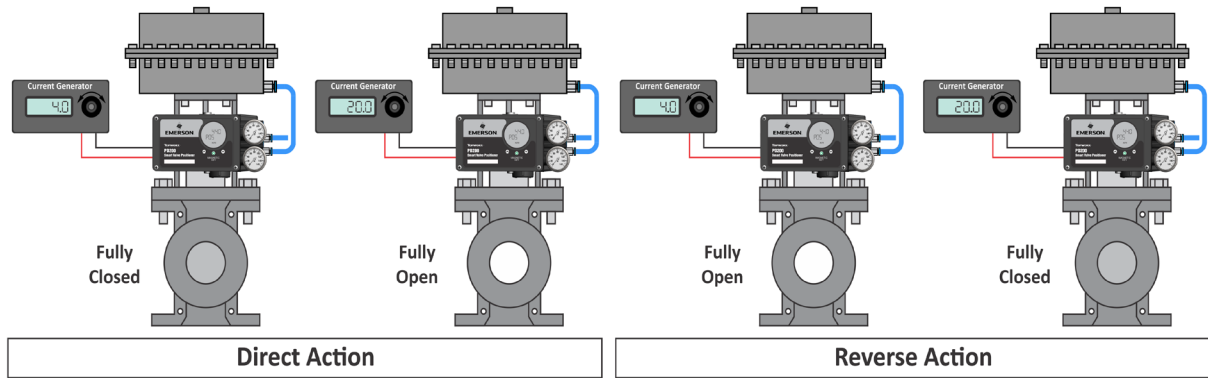

**Figure 8-29 Action Menu**

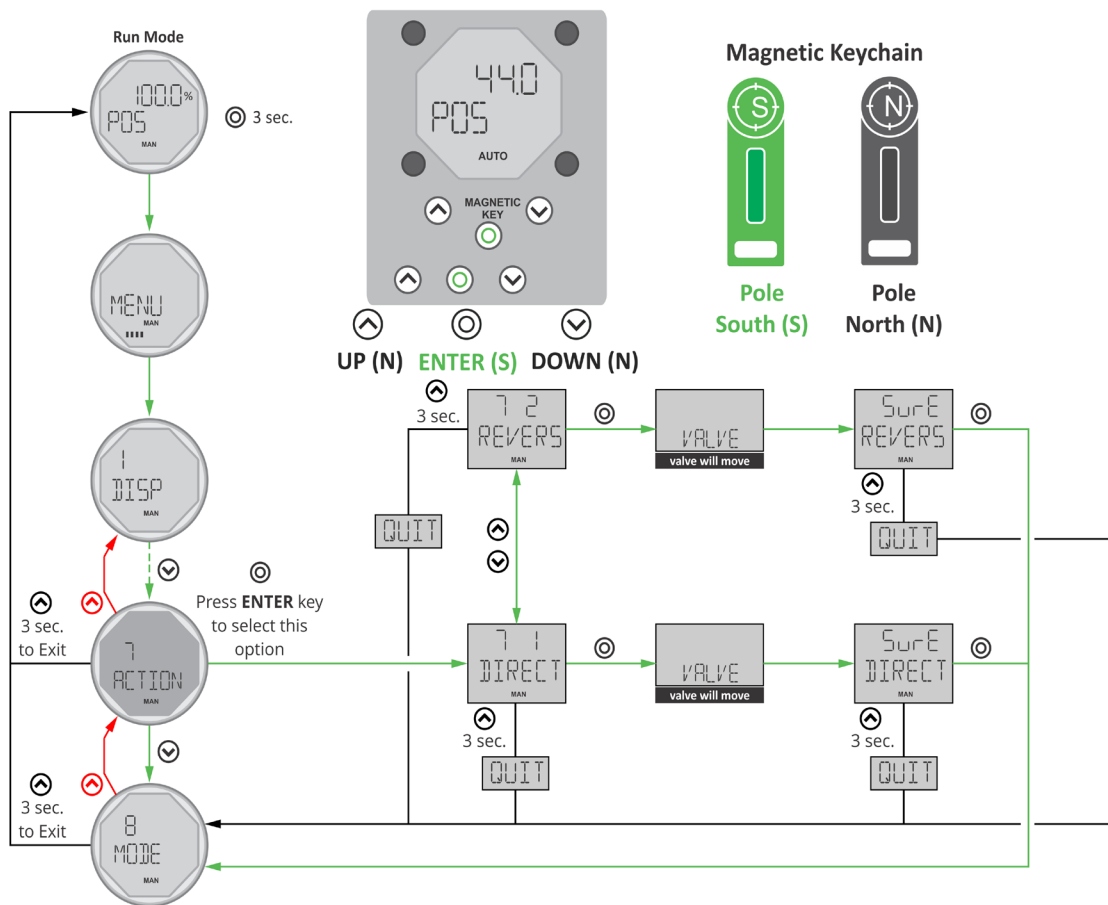

### Accessing the Action Menu

- Press ENTER ○ for 3 seconds to enter the menu.
- Use the DOWN key to go to the ACTION option. The UP key returns to the previous option.
- Use the UP or DOWN keys to select an option.
- Press ENTER ○ to select the option.
- Use the UP or DOWN keys to select the "DIRECT" or "REVERS" option.
- Press ENTER ○ to select the option.
- To proceed with the selected option, use the ENTER ○ key.
- If you do not want to proceed with the selected option, use the UP key for 3 seconds.
- If you want to exit the ACTION menu options, use the UP key for 3 seconds and return to the main menu.

## 8.5.8 Mode Menu

In this function, it is possible to define the valve operation mode:

**8.1 - AUTO:** The valve operates in automatic mode.

**8.2 - MAN:** The valve operates in manual mode and can be moved to 0%, 25%, 50%, 75%, 100% and "ADJUST". (value freely adjustable by the user).

Figure 8-30 Mode Menu

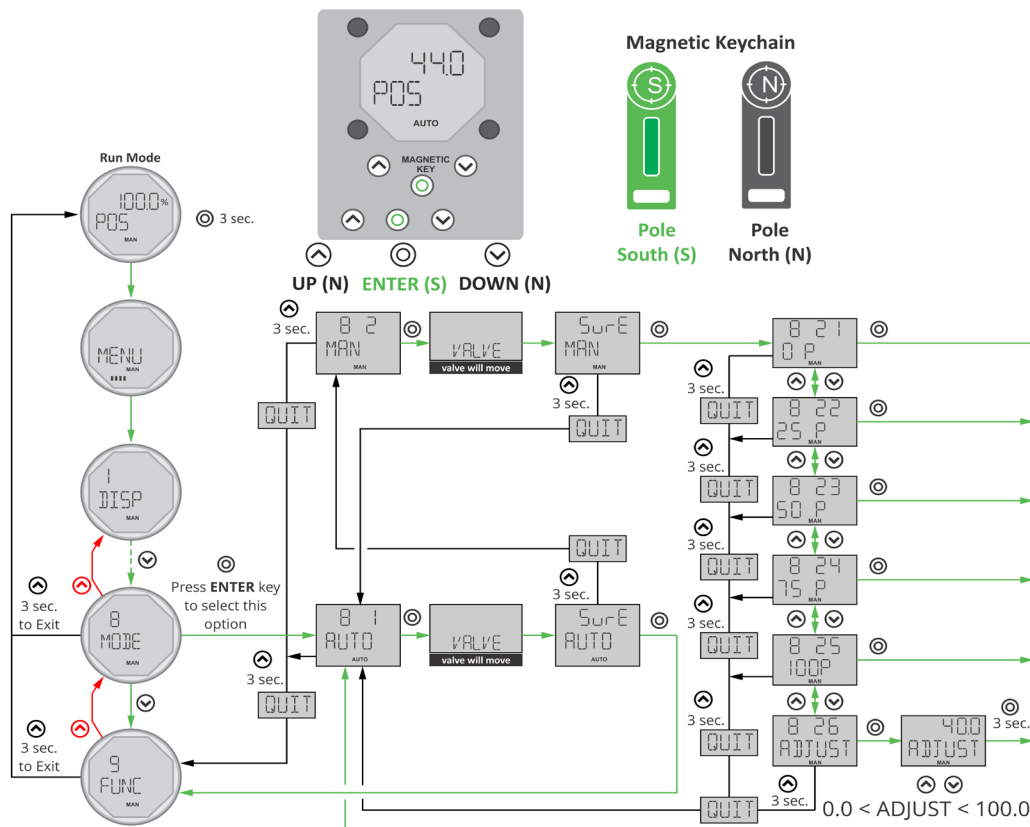

### Accessing the Mode Menu

- Press ENTER  $\circ$  for 3 seconds to enter the menu.
- Use the DOWN key to go to the MODE option. The UP key returns to the previous option.
- Use the UP or DOWN keys to select an option.
- Press ENTER  $\circ$  to select the option.
- Use the UP or DOWN keys to select the "AUTO" or "MAN" option.
- Press ENTER  $\circ$  to select the option.
- If you select "AUTO", confirm with ENTER  $\circ$ . The display will show SURE.
- To proceed with the selected option, press ENTER  $\circ$ . The unit executes the option and goes to the next menu.
- If you are NOT SURE to proceed, press the UP arrow key for 3 seconds. The unit will go to the "MAN" option.
- Press the ENTER  $\circ$  key to select the option.
- Use the UP or DOWN keys to select an option.
- There are five fixed options and one adjustable option. Press the ENTER  $\circ$  key on the desired option.
- In the "ADJUST" option, use the ENTER  $\circ$  key to select the digit and the UP or DOWN keys to increase or decrease the value. Hold to quickly increase or decrease the value.
- When the value is ready, store it with the ENTER  $\circ$  key for 3 seconds.
- To exit the option and return to the main menu, press the UP key for 3 seconds.

## 8.5.9 FUNC Menu

It allows the user to configure the positioner's performance according to the Setpoint value, using pre-established system flow characterization functions which are described below:

**9.1 - LIN:** Linear Curve.

**9.2 - EP25:** Equal Percentage Curve.

**9.3 - EP33:** Equal Percentage Curve.

**9.4 - EP50:** Equal Percentage Curve.

**9.5 - QO25:** Quick Opening Curve. Hyperbolic.

**9.6 - QO33:** Quick Opening Curve. Hyperbolic.

**9.7 - QO50:** Quick Opening Curve. Hyperbolic.

Equal Percentage (EP): This function characterizes the output according to a percentage increase in flow over its previous value. This percentage can be 25%, 33% or 50%, which causes a logarithmic curve as shown in the figure beside.

Fast Aperture (QO): This function characterizes the output according to a high flow increment, also in a percentage way (25%, 33% or 50%) over a small variation in the input signal, which causes a logarithmic curve as shown in the next figure.

Figure 8-31 Characteristic Curve

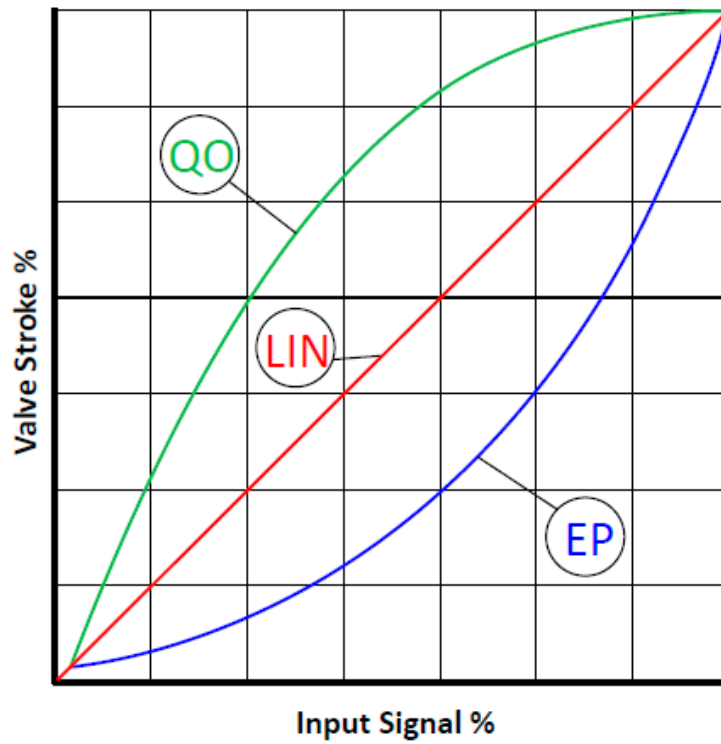
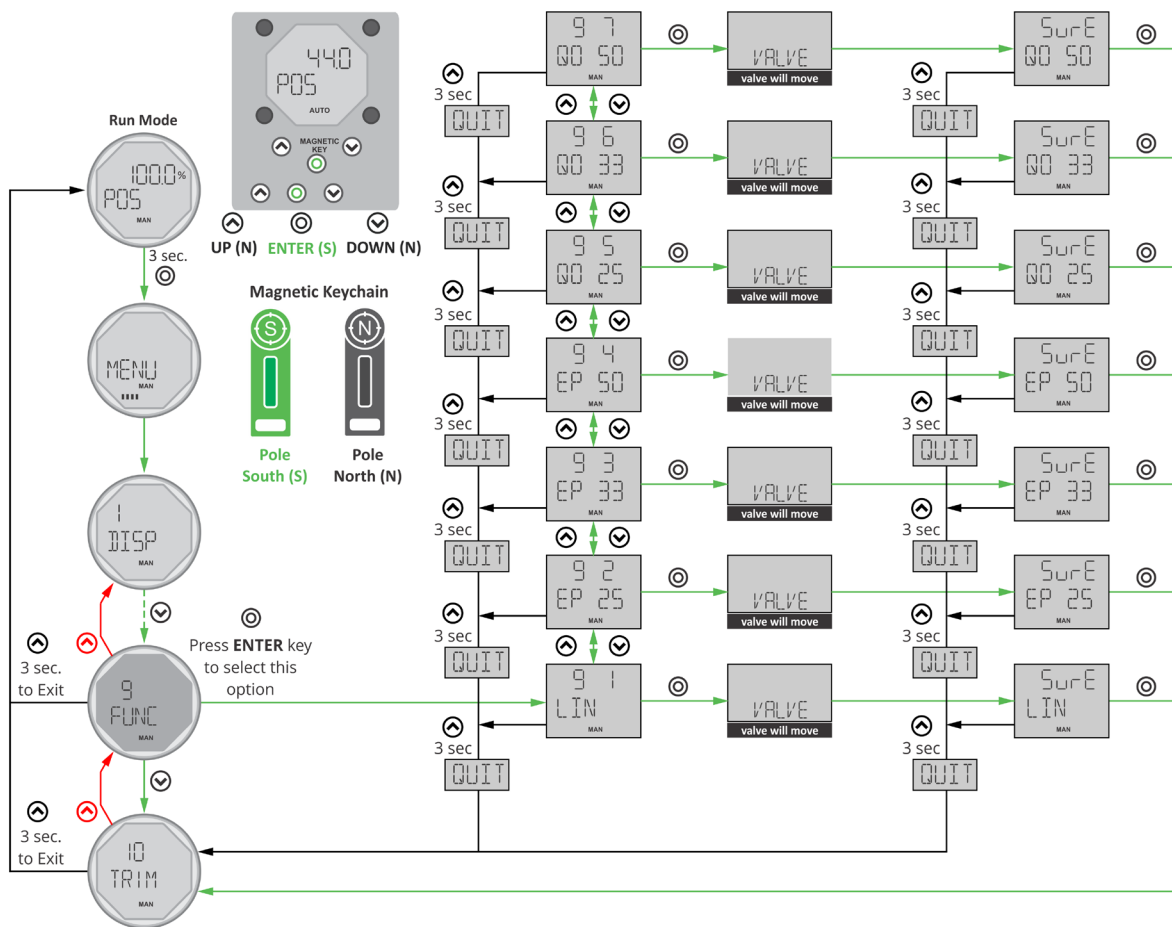

Figure 8-32 FUNC Menu



Accessing the FUNC Menu

- Press ENTER  $\circ$  for 3 seconds to enter the menu.
- Use the DOWN key to go to the FUNC option. The UP key returns to the previous option.
- Use the UP or DOWN keys to select an option.
- Press ENTER  $\circ$  to select the option.
- To proceed with the selected option, confirm with the ENTER  $\circ$  key.
- If you do not wish to proceed with the selected option, use the UP key for 3 seconds.

## 8.5.10 Trim Menu

It allows correcting a small variation in the 4-20 mA signal. See the example below:

- 4:** Set the input current as 0% closed valve.
- 20:** Set the input current as 100% closed valve.

**Figure 8-33 TRIM Adjustment Example**

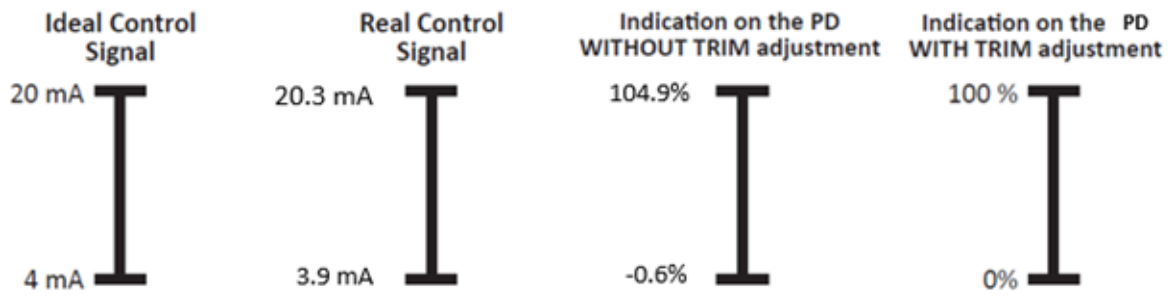

To make the adjustment, follow the procedure below:

**Figure 8-34 TRIM Menu**

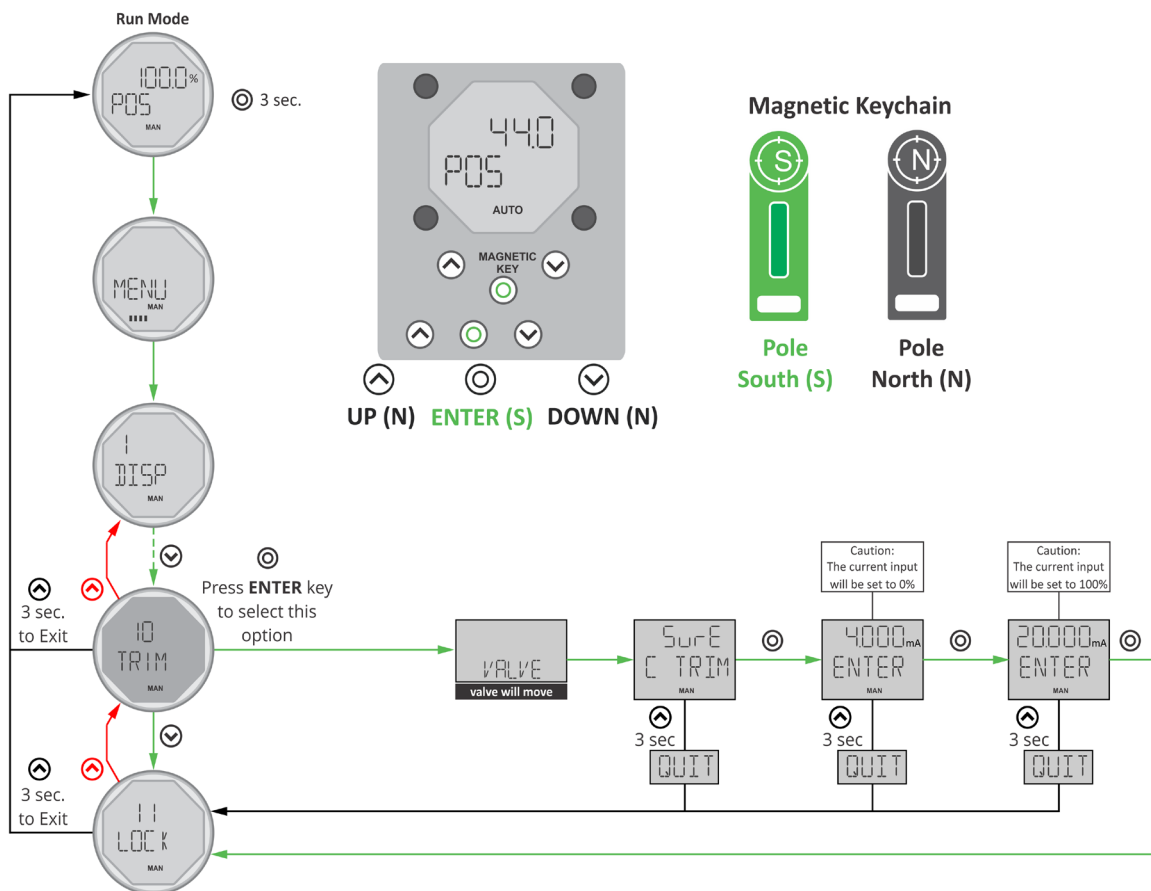

### Accessing the TRIM Menu

- Press ENTER  $\circ$  for 3 seconds to enter the menu.
- Use the DOWN key to go to the TRIM option. The UP key returns to the previous option.
- Use the ENTER key  $\circ$  to select the option.
- Set the control signal to 4 mA, then confirm the 4 mA point with the ENTER  $\circ$  key.
- Adjust the control signal to 20 mA and also confirm the 20 mA point with the ENTER  $\circ$  key.
- If you wish to exit the menu without making changes, DO NOT use ENTER  $\circ$ , use the UP key for 3 seconds and return to the main menu.

### Feedback Output Test

The feedback signal is automatically obtained in the positioner calibration process. It is possible to measure this signal to check possible differences between the control and feedback signals before putting the positioner into operation.

To test the signal, connect a 4 to 20 mA current generator to terminals 1 (+) and 3 (-). Connect a 24 Vdc voltage source in series with a multimeter on the current scale at terminals 4 (+) and 5 (-).

**Figure 8-35 Feedback Test Link**

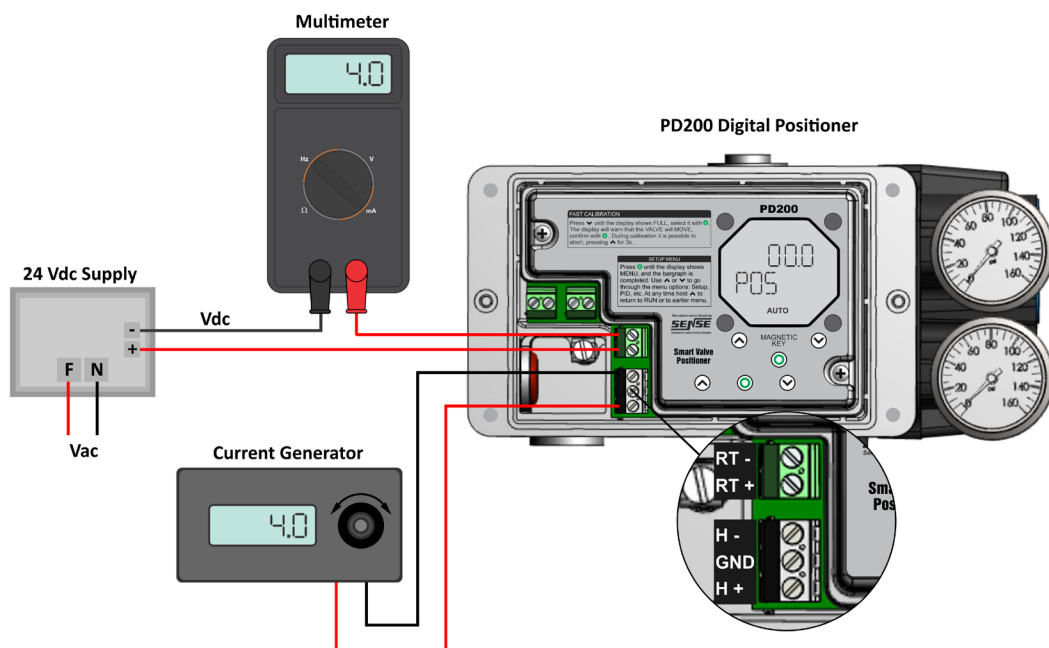

Set the current generator to 4 mA and gradually increase by checking the output signal (feedback) on the multimeter. See the graph below for 4 to 20 mA current values.

The output signal must be the same as the current generator, if there is a difference, perform the TRIM adjustment procedure indicated in the previous item.

Figure 8-36 Feedback Signal Graph

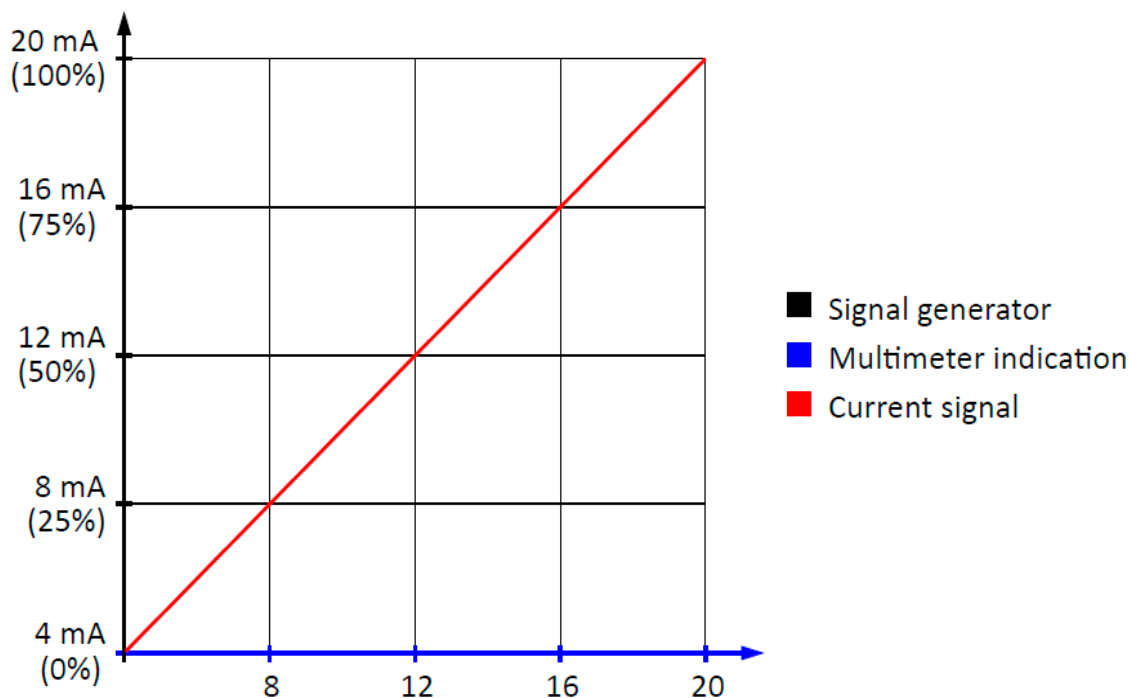

## 8.5.11 Lock Menu

In this menu function, the user has 2 operating modes:

**11.2 - LOCK:** Prevents the alteration of any positioner setting, preventing unauthorized persons from modify the operation.

**11.2 - UNLOCK:** It may be used to perform the configuration either via local mode or remote mode.

Figure 8-37 LOCK Menu

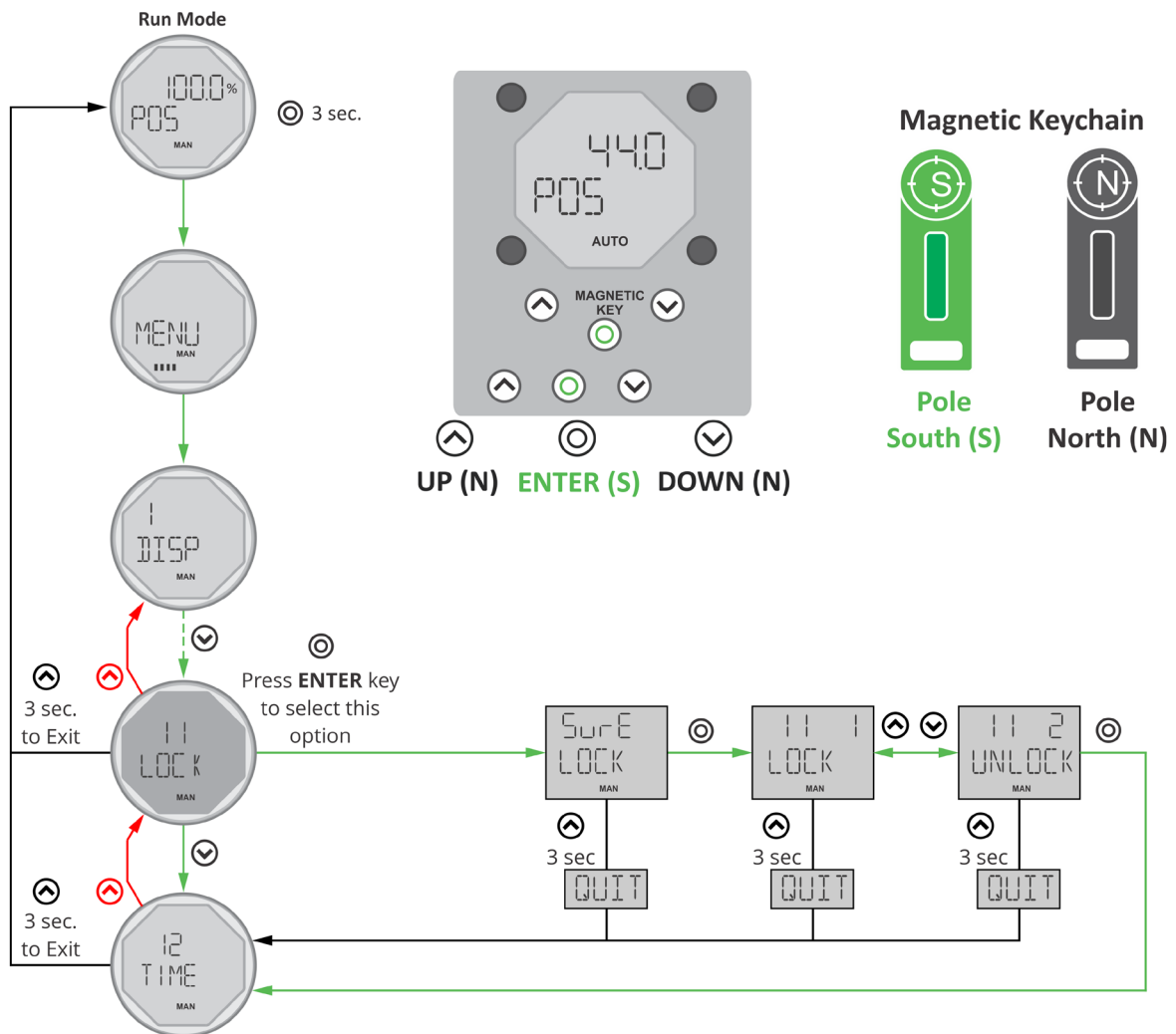

### Accessing the LOCK Menu

- Press ENTER  $\circ$  for 3 seconds to enter the menu.
- Use the DOWN key to go to the LOCK option. The UP key returns to the previous option.
- Use the ENTER  $\circ$  key to select the option. The display will show SURE.
- To enter this function, use the ENTER  $\circ$  key.
- Use the UP or DOWN key to change the option.
- Use the ENTER  $\circ$  key on the desired option.

## 8.5.12 Time Menu

This function is designed to store the maximum angle and times it takes for the valve to open and close completely for future diagnostic purposes. The opening and closing times and the maximum angle are stored each time a FULL or AUTO calibration is performed, and these values will remain stored until a new calibration updates the new conditions. Please note that during normal operation of the positioner the TIME function does not remeasure these parameters, not least because the positioner hardly ever travels the entire stroke in the control phase.

### Examples:

Opening time 16.25 seconds, from fully closed 0% to fully open 100%

---

**Figure 8-38 Opening Time Stored in Calibration**



Closing time of 6.74 seconds, from fully open 100% to fully closed 0%.

---

**Figure 8-39 Closing Time Stored in Calibration**



**Figure 8-40 TIME Menu**

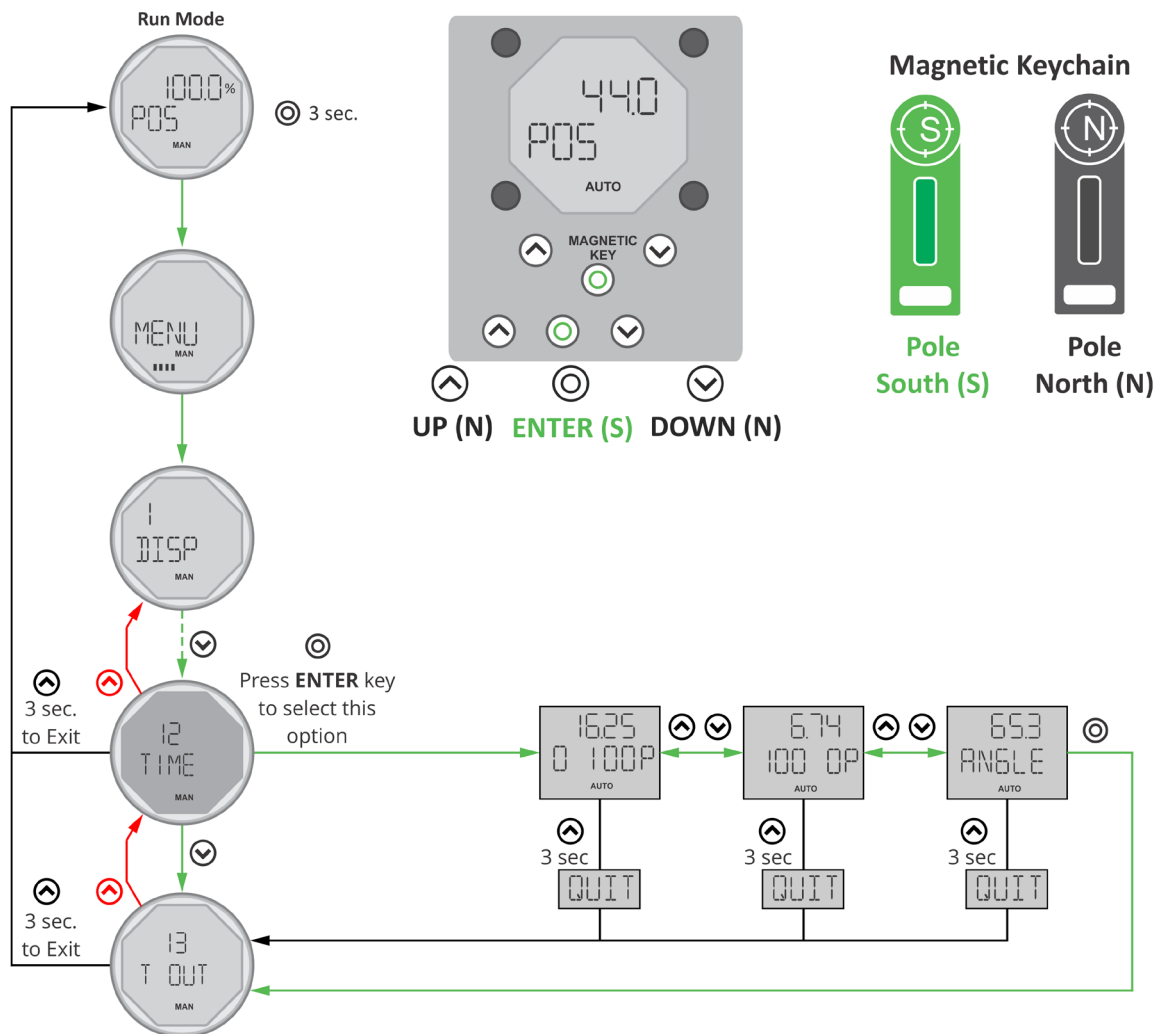

**Accessing the TIME Menu**

- Press ENTER  $\circ$  for 3 seconds to enter the menu.
- Use the DOWN key to go to the TIME option. The UP key returns to the previous option.
- Use the ENTER key  $\circ$  to select the option.
- Use the UP or DOWN keys to select "0 100P", "100 0P" or "Angle".
- Confirm the selection with the ENTER  $\circ$  key.
- The unit shows the opening, closing or angle time and goes to the next "TIMEOUT" option.
- To exit the menu, use the UP key for 3 seconds.

## 8.5.13 T OUT MENU

This option allows you to adjust the time the positioner uses to perform the calibration. The time of the positioner is programmed at the factory for 10 seconds but can be set from 10 to 120 seconds.

Figure 8-41 TIMEOUT Menu

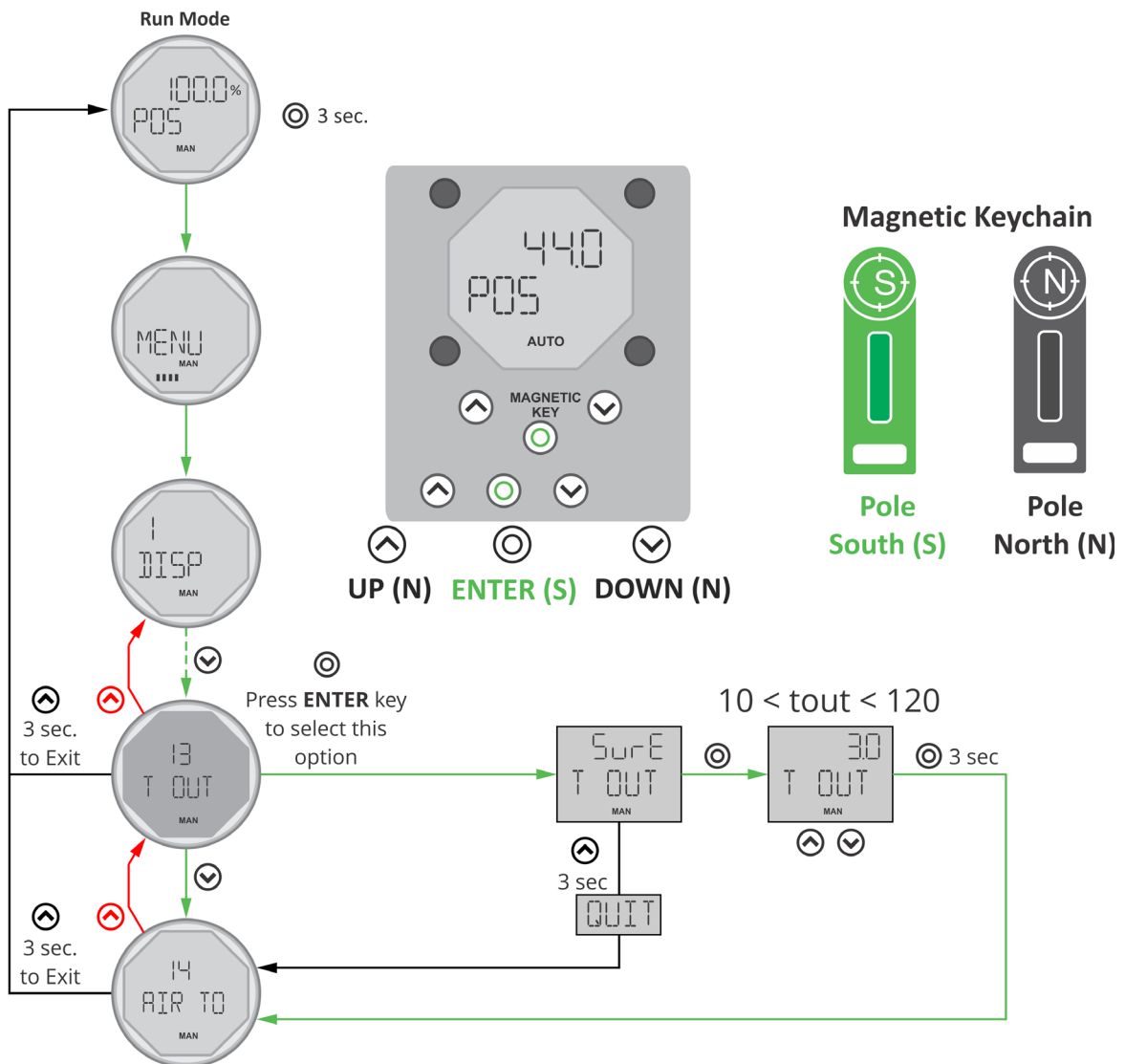

### Accessing the T OUT Menu

- Press ENTER  $\circ$  for 3 seconds to enter the menu.
- Use the DOWN key to go to the T OUT option. The UP key returns to the previous option.
- Use the ENTER  $\circ$  key to select the option. The display will show SURE.
- To continue, use the ENTER  $\circ$  key.
- Use the ENTER  $\circ$  key to select the digit and the UP or DOWN keys to change the digit.
- When the value is ready, confirm with the ENTER  $\circ$  key for 3 seconds.
- If you want to exit without any change, use the UP key for 3 seconds and return to the main menu.

---

### IMPORTANT

Large valves and actuators may require longer T OUT time because valve movement takes longer.

---

### Calibration Failure Alarm - Tout Alert

A failure is indicated if the valve does not respond within the time set in the menu. Three consecutive failures must occur for the positioner to indicate an alarm.

Tout Alert can occur in three cases during the calibration process:

#### 1 - Lack of initial movement:

Let's assume that Tout was set to 10 seconds, and for some reason during the self-calibration process the actuator does not move its axis, example: lack of air, wrong pneumatic connection, stuck valve, etc. When you start the calibration procedure, the Tout time starts counting with the display indicating 0%, and from this moment on we have the following steps:

**A** - Display showing 0% - At this point, the positioner will send a command for the actuator to move to the rest position and wait 10 seconds (Tout set) then it logs internal fault 1, as there was no movement.

**B** - Now the display changes to 5% - and the positioner sends a new command for the actuator to go to position A (example: Open), and after 10 seconds it accumulates internal fault 2, since there was no movement either.

**C** - Then the display shows 10% - and the positioner sends a new command for the actuator to move to position B (example: Closed).

**D** - Tout Alert is triggered generating an initial lack of movement fault. Note that only after internal faults 1, 2, and 3 is the Tout Alert generated. Notice that it took 30s after the start of the auto calibration routine, or 3 times the Tout set in the menu, for the Tout Alert to be generated. If in this case the Tout set was 120 seconds, the lack of initial movement alarm would only be generated after 360 seconds.

#### 2 - Actuator pressurization delay condition:

Imagine the case of an actuator that takes 100 seconds to fully open and starts its movement only from 90 seconds after the start of pressurization of its chamber.

In this case if the Tout is kept at 10 seconds, the display will indicate the steps 0%, then 5% and 10% and after the initial 30 seconds the Tout Alert will be generated, because the actuator has not had time to start the movement of its axis, due to lack of pressurization of the chamber.

In situations where this failure condition occurs, it is necessary that the user "reset" Tout to a minimum value of 100 seconds.

### **3 - Failure in the learning cycles of the open and closed points:**

Imagine the condition where Tout is set to 10 seconds and that the set (positioner/actuator) was able to perform the 1st cycle of learning the open and closed points, but when starting the second or third cycle, a failure of lack of compressed air occurs. In this case, the Tout Alert will only be generated at the end of the self-calibration process of the Open and Close positions.

**A** - Display showing 0% - At this point the positioner will send a command for the actuator to go to the rest position and wait 10 seconds (Tout set), action successfully performed within the 10-second interval.

**B** - Now the display changes to 5% - and the positioner will send a new command for the actuator to go to position A (example: Open), action successfully accomplished within the 10-second interval.

**C** - Then the display changes to 10% - and the positioner sends a new command for the actuator to go to position B (example: Open), action successfully accomplished within 10 seconds.

**D** - The display changes to 15% - and the positioner sends a new command for the actuator to go to position A (example: Open), and after the 10 seconds elapsed, internal fault 1 occurs - because there was no movement.

**E** - Then the display changes to 20% - and the positioner sends a new command for the actuator to go to position A (example: Open), and after the 10 seconds elapsed internal fault 2 occurs - because there was no movement either.

**F** - The display now shows 25% - and the positioner sends a new command for the actuator to go to position A (example: Open), and after the 10 seconds elapsed internal fault 3 occurs - because there was no movement either.

**G** - The display now shows 30% - and the positioner sends a new command for the actuator to go to position A (example: Open), and after the 10 seconds internal fault 4 occurs - because there was no movement either.

**H** - Tout Alert is activated, but note that it now took 70 seconds for the alert to be generated, i.e. 7 times the Tout set in the menu, because the first 3 steps of the 1st learning cycle were successful and the positioner only registered the problem in the 2nd cycle and confirmed the lack of movement in the 3rd cycle.

## **8.5.14 AIR TO Menu**

This function allows to invert the indication of the percentage of open position to percentage of close position, matching the display indication with the actual valve position. If for any reason the position of the pneumatic connections are reversed in the actuator, you can return the same indication in the display as before the hoses were changed with the AIR TO function.

See the example, with the setpoint at 25%.

**Set to Air to OPEN:**

---

**Figure 8-42 Air to Open**



**Set to Air to CLOSE:**

---

**Figure 8-43 Air to Close**



**Figure 8-44 AIR TO Menu**

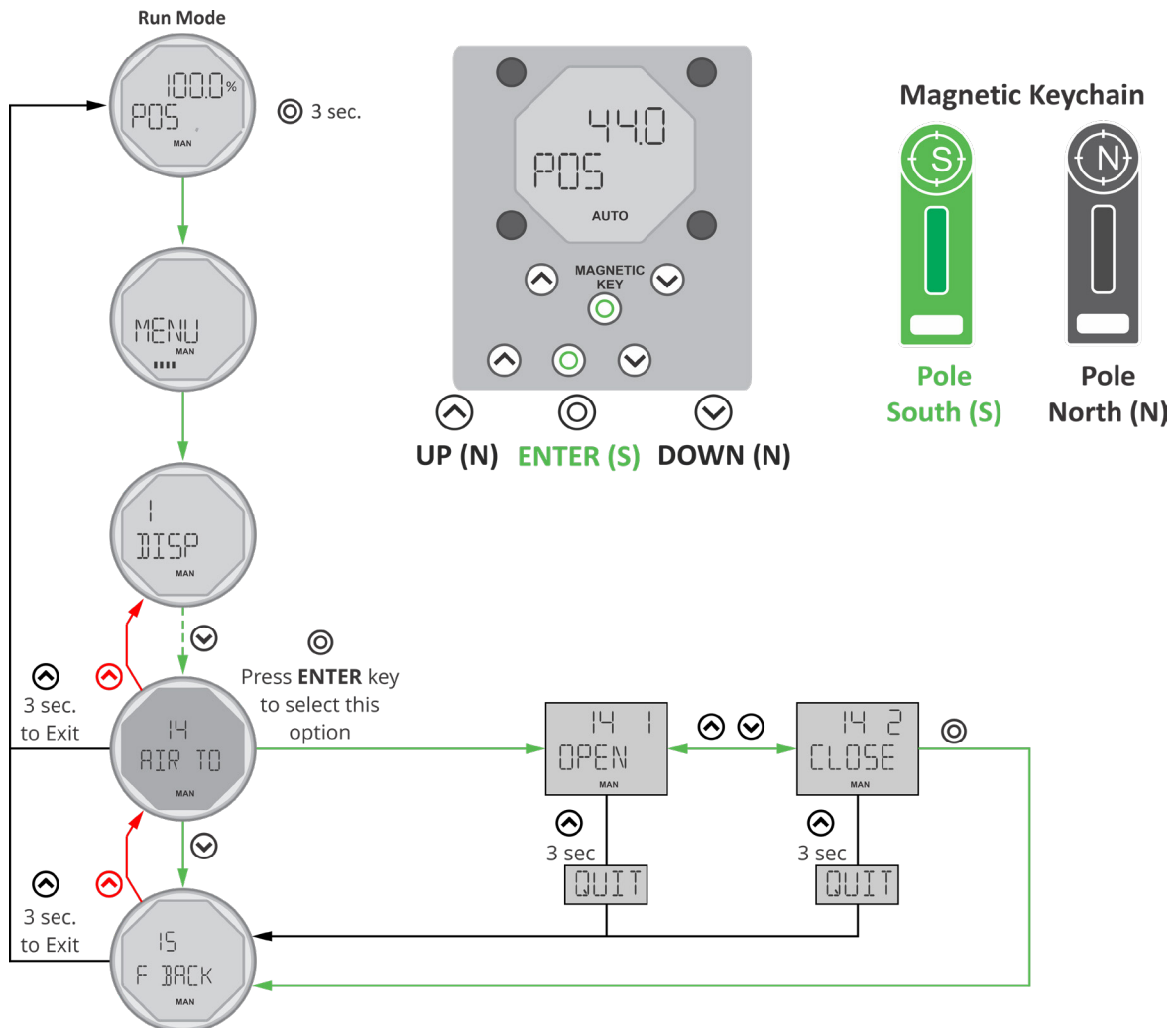

**Accessing the AIR TO Menu**

- Press ENTER  $\circ$  for 3 seconds to enter the menu.
- Use the DOWN key to go to the AIR TO option. The UP key returns to the previous option.
- Press ENTER  $\circ$  to select the option.
- Use the UP or DOWN keys to select the option.
- Press ENTER  $\circ$  to confirm the option.
- If you wish to exit without any changes, use the UP key for 3 seconds and return to the main menu.

## 8.5.15 F BACK Menu

This function sets the feedback output condition to low, high, or last, in case of loss of the setpoint signal.

When the current from the setpoint input is turned off, and at the instant the current drops below 3.6 mA, the feedback fail function sends to the feedback output the current according to the following options:

**LOW:** The feedback output current goes to < 3.6 mA, a condition that indicates that valve closure (or opening as defined in the ACTION function) and as the current is below 4 mA it still indicates a fault condition for controller.

**HIGH:** The feedback output current goes to > 22.5 mA, a condition that indicates the valve opening (or closing as defined in the ACTION function) and as the current is above 20 mA it still indicates a fault condition for controller

**LAST:** In this case the feedback output is "frozen" at the exact value it was at the moment the setpoint signal was lost.

**Figure 8-45 F BACK Menu**

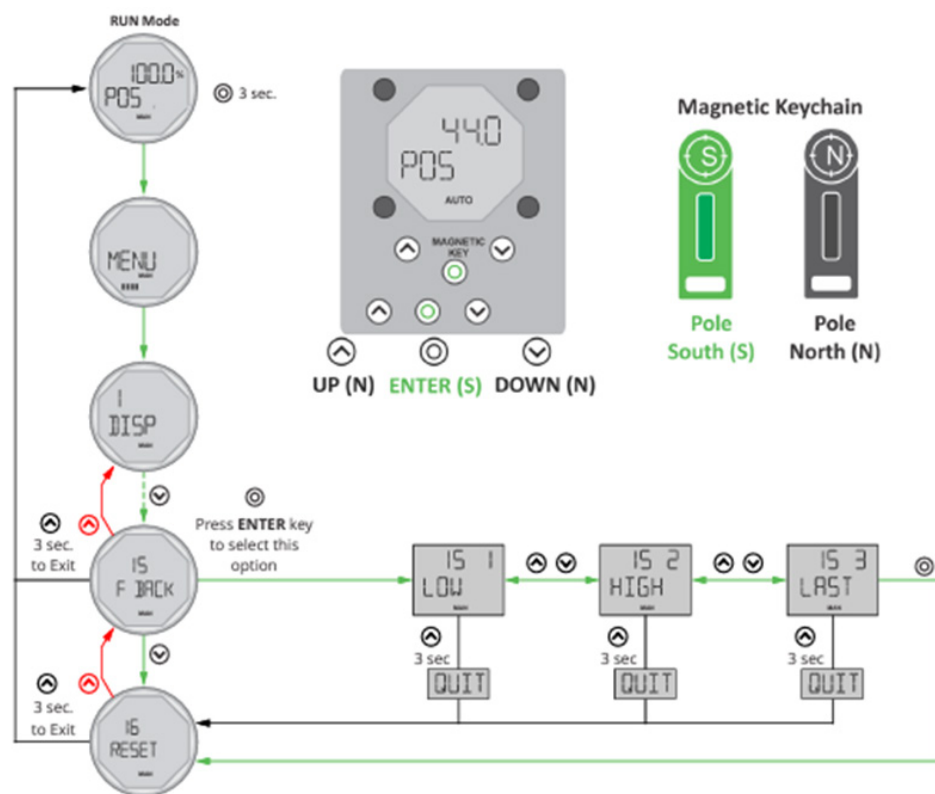

### Accessing the F BACK Menu

- Press ENTER ◯ for 3 seconds to access the menu.
- Press the DOWN arrow key to go to F BACK option. Press the UP arrow key to go back to the previous option.
- Press ENTER ◯ to select the option.
- Press UP or DOWN arrow keys to select the option.
- Press ENTER ◯ to confirm the option.
- If you wish to exit without any changes, press the UP arrow key for 3 seconds.

## 8.5.16 RESET Menu

In this menu function, all default values can be restored.  
SURE: Returns the factory settings. QUIT: Returns to the main menu without resetting.

**Figure 8-46 RESET Menu**

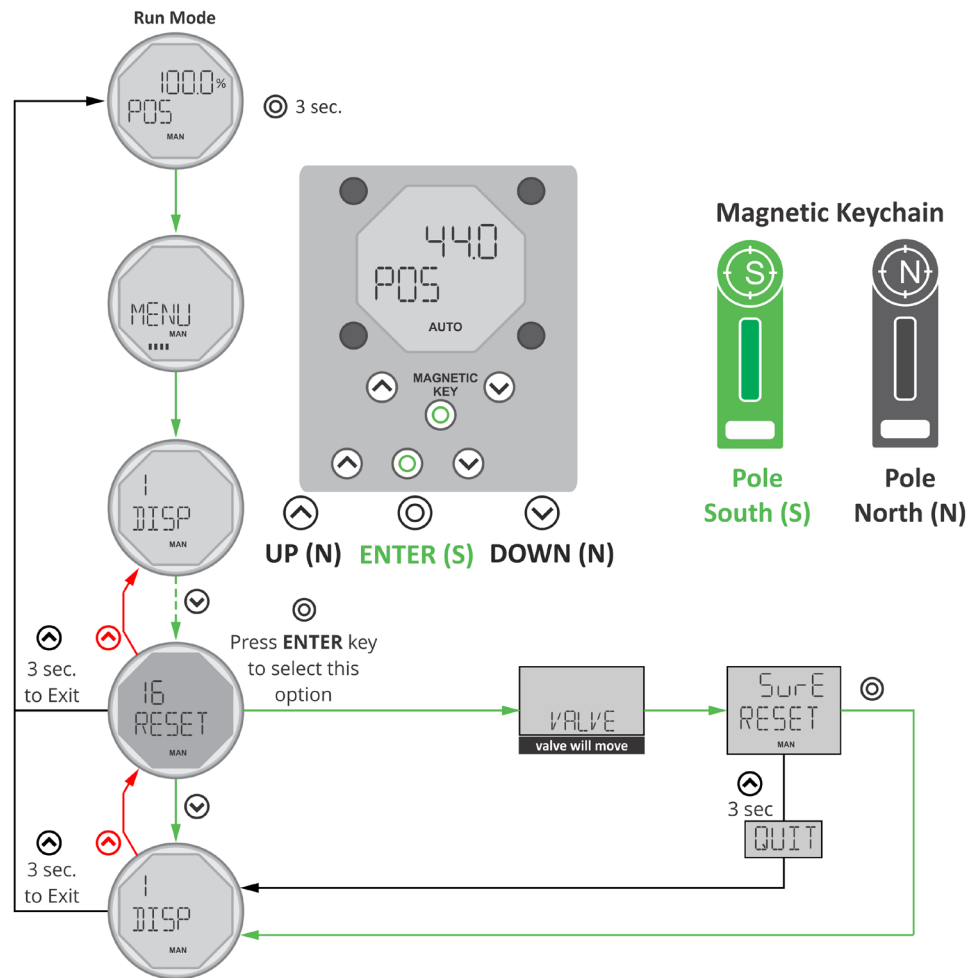

### Accessing the RESET Menu

- Press **ENTER** ○ for 3 seconds to enter the menu.
- Use the **DOWN** key to go to the **RESET** option. The **UP** key returns to the previous option.
- Press **ENTER** ○ to select the option. The display will show **SURE**.
- To proceed with **RESET**, use the **ENTER** ○ key
- If you do not wish to proceed with **RESET**, use the **UP** key for 3 seconds.

### Factory Standard

When performing the reset, the following parameters will be changed:

---

**Figure 8-47 Factory Defaults (Standards)**

Parameter	Factory Standard
Disp	SP
Range	Zero: 0% SPAN: 100%
SPLT	Disabled
Action	Disabled
Mode	Auto
Func	Lin
Air to	Open
T Out	10 seconds

---

## 8.5.17 VER Menu

The VER function displays the current loaded software version for the device. The current version is also displayed briefly when the positioner is first powered up or when restarted after a disruption in power.

**Figure 8-48 Software Version Menu**

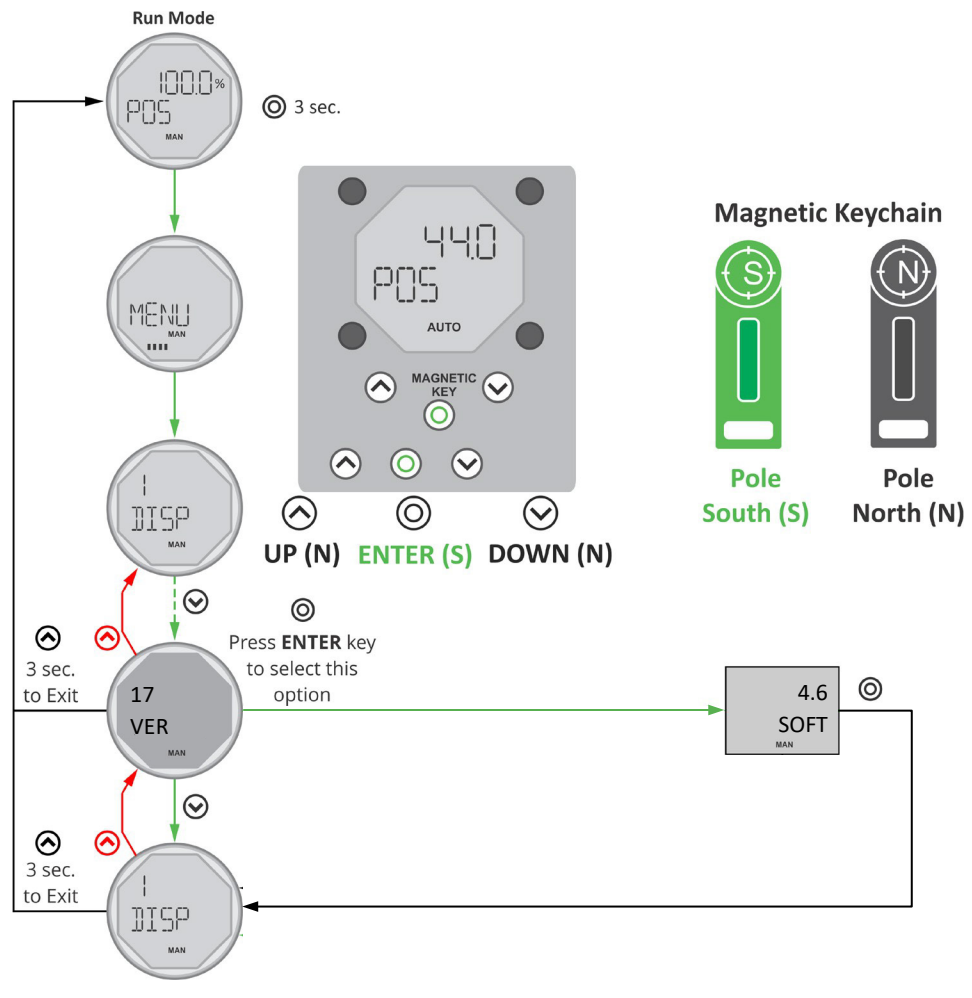

## Section 9: Certifications

### Intrinsically Safe:

USL/CNL Class I, Division 1, Group ABCD; Class II, Division 1, Group EFG  
T4, T135°C - UL File E125326  
UL 23ATEX3095X / IECEx UL 23.0075X

 II 1 G Ex ia IIC T4 Ga;  
II 2 D Ex ia IIIC T135°C Db; -40°C ≤ Tamb ≤ +65°C

### General Purpose:

USL/CNL General Purpose  
UL File E359150

### Environmental Ratings: Type 4X, IP66

Operating and Ambient temperature ratings vary depending on materials of construction.  
Reference certificate for specific markings available.

**Conformance to Directives:** ATEX 2014/34/EU, EMC 2014/30/EU, LVD 2014/35/EU

### Conformance to International Standards:

- UL 913 - Intrinsically Safe Apparatus and Associated Apparatus for Use in Class I, II, and III, Division 1, Hazardous Locations.
- UL 50E - Enclosures for Electrical Equipment, Environmental Considerations.
- CSA-C22.2 No. 60079-0:19 - Explosive atmospheres - Part 0: Equipment - General requirements
- CSA C22.2 No. 94.2:20 - Enclosures for Electrical Equipment, Environmental Considerations.
- CAN/CSA-C22.2 No. 60079-11:14 - Explosive atmospheres - Part 11: Equipment protection by intrinsic safety "i"
- IEC 60079-0 Ed. 7 - Explosive atmospheres - Part 0: Equipment - General requirements.
- IEC 60079-11 Ed. 6 - Explosive atmospheres - Part 11: Equipment protection by intrinsic safety "i"
- IEC 61514-2, IEC 61000-4-3, and complementary test - Immunity to Radiated Electromagnetic Fields.
- IEC 61000-4-4 and IEC 61514-2, clause 5.5.2 - BURST Fast Transients.
- According to IEC 61326-1 and IEC 61326-2-3, Table 2, acceptance criteria B.
- IEC 61000-4-8 and IEC 61514-2, clause 5.5.2 - Magnetic Fields.
- IEC 61000-4-2 e IEC 61514-2, item 5.5.2 - Electrostatic Discharge.
- IEC 61000-4-6 - Immunity to conducted disturbances, induced by radiofrequency fields.
- IEC 61000-4-5 - Surge Immunity Test - PD200: input 4 to 20mA:1 kV - Line to ground. Feedback 4 to 20 mA, PNP1 and PNP2: 1kV Line to Line.
- EN IEC 60079-0:2018 – Explosive atmospheres – Part 0: Equipment – General requirements
- EN 60079-11:2012 – Explosive atmospheres – Part 11: Equipment protection by intrinsic safety "i"

### Pending:

- REACH/RoHS Compliant

### Specific Conditions of Use:

- Clean with a damp cloth before touching or servicing to avoid electrostatic discharge. See installation instructions for further guidance.
- Equipment has only been evaluated for low risk of mechanical impact. Equipment shall only be installed in areas where the risk for mechanical impact is low.
- External parts of the device contain aluminum. Care shall be taken to avoid sparking hazards due to impact.

## 9.1 Installation in Potentially Explosive Atmosphere

The PD200 positioner is intended for installation in potentially explosive atmospheres and is designed to meet IEC / EN 60079-0, IEC / EN 60079-11 intrinsic safety standards. Before installing the instrument, it is necessary to pay attention to the parameters of the entity and ensure that the positioner is installed with an intrinsic safety barrier suitable for operating with positioners.

### **⚠ DANGER**

- Always separate intrinsically safe (IS) circuits from non-intrinsically safe (NIS) circuits.
- Always install the positioner with a suitable intrinsically safe barrier.
- Check the entity parameters of the positioner. See Section 9.1 - Entity Parameters.
- Protect cables from external impacts.
- Grounding the positioner is of utmost importance and highly recommended.
- Potential risk of electrostatic charge, clean only with damp cloth.

### 9.1.1 Entity Parameters

In intrinsically safe installations, one must pay attention to the entity parameters. Entity parameters are information of intrinsically safe instruments, field elements and associated intrinsically safe instruments (Ex i barriers) that allow the instruments to be interconnected or not.

For all the instruments to be safely interconnected, some conditions must be met.

#### **Positioner Parameters**

- U<sub>i</sub>** - Maximum input voltage
- I<sub>i</sub>** - Maximum input current
- P<sub>i</sub>** - Input power
- C<sub>i</sub>** - Maximum Internal Capacitance
- L<sub>i</sub>** - Maximum internal inductance

#### **Barrier Parameters**

- U<sub>o</sub>** - Max. open circuit voltage
- I<sub>o</sub>** - Max. short-circuit current
- P<sub>o</sub>** - Maximum output power
- C<sub>o</sub>** - Maximum external capacitance
- L<sub>o</sub>** - Maximum external inductance
- U<sub>m</sub>** - Maximum voltage at non-Ex terminals

#### **Interconnection Position x Barrier**

- U<sub>i</sub> ≥ U<sub>o</sub>**
- I<sub>i</sub> ≥ I<sub>o</sub>**
- P<sub>i</sub> ≥ P<sub>o</sub>**
- C<sub>i</sub> + C cable ≤ L<sub>o</sub>**
- L<sub>i</sub> + L cable ≤ L<sub>o</sub>**

#### **Intrinsically Safe Entity Parameters:**

##### **Analog 4-20mA Input:**

U<sub>i</sub>=28V, I<sub>i</sub>=93mA, P<sub>i</sub>=651mW, C<sub>i</sub>=22nF, L<sub>i</sub>=0μH

##### **Analog 4-20mA Output:**

U<sub>i</sub>=28V, I<sub>i</sub>=93mA, P<sub>i</sub>=651mW, C<sub>i</sub>=0nF, L<sub>i</sub>=0μH

##### **Alarm Switches (Connectors CN4 and CN5):**

U<sub>i</sub>=28V, I<sub>i</sub>=93mA, P<sub>i</sub>=2W, C<sub>i</sub>=0nF, L<sub>i</sub>=0μH

## 9.1.2 Example of Intrinsically Safe Connection

Figure 9-1 Example of Intrinsically Safe Connection

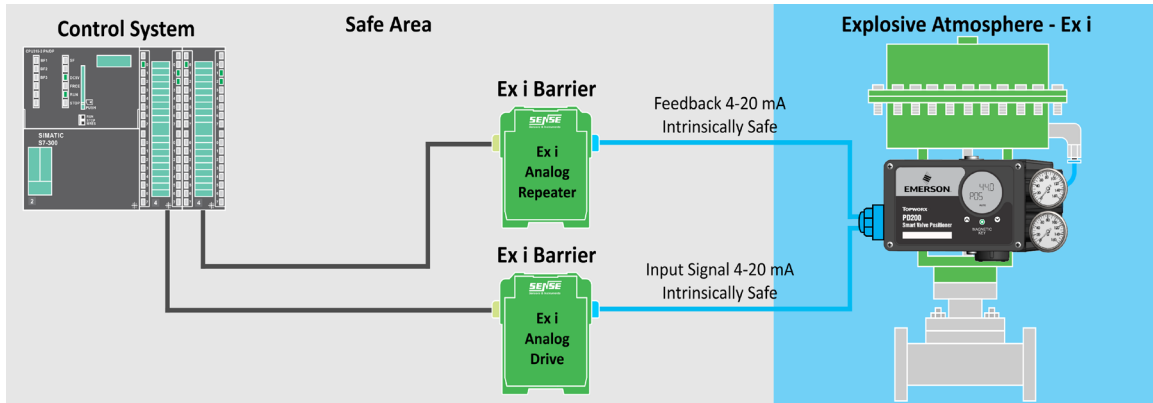
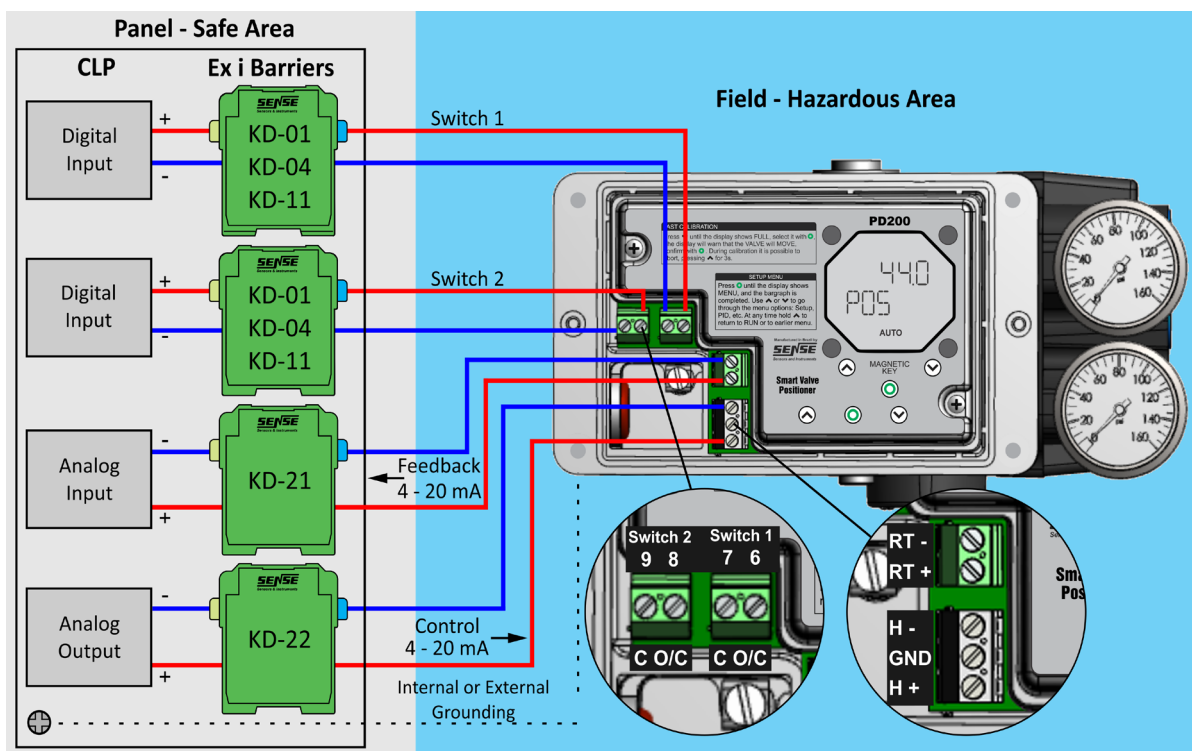
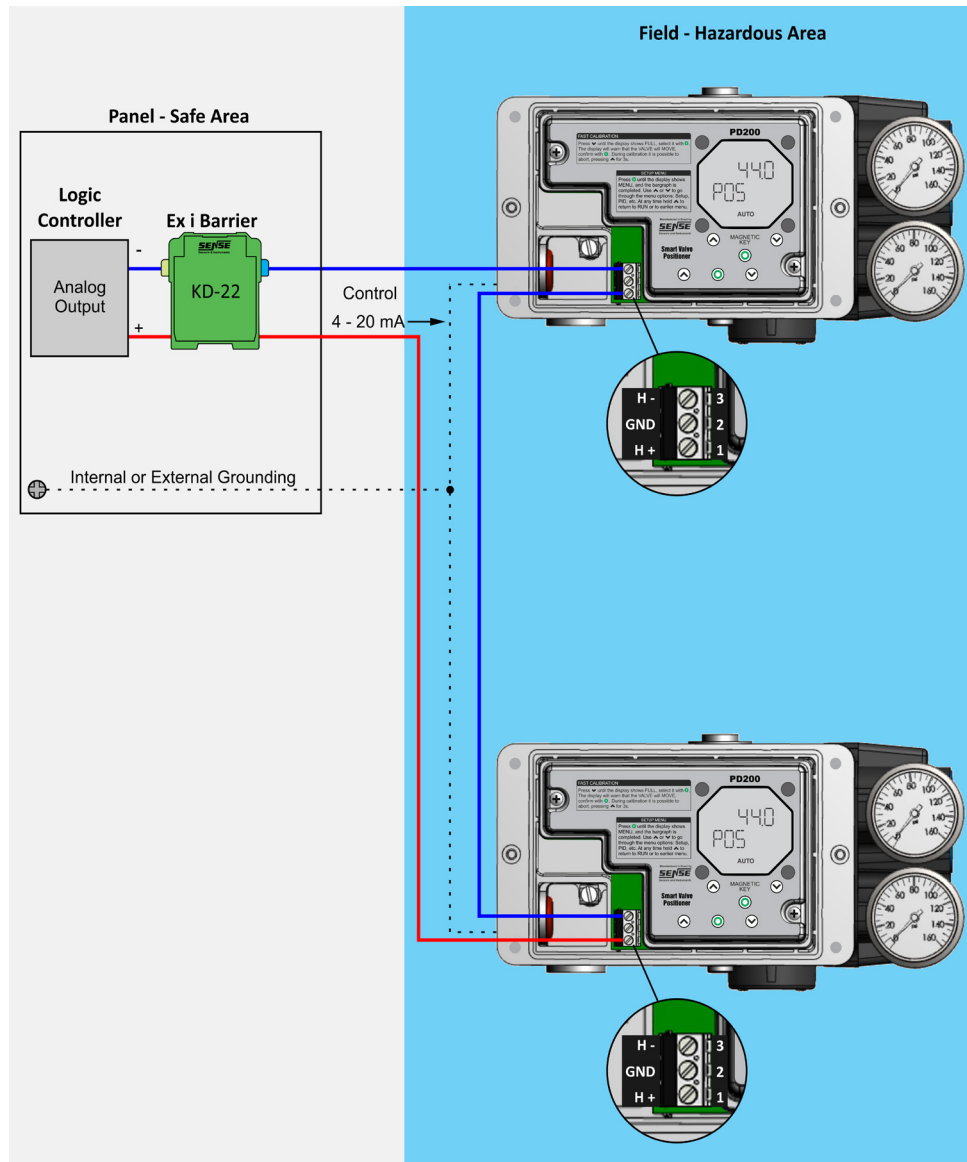

Figure 9-2 Positioner with Micro Alarm Switch and Feedback



**Figure 9-3 Split Range Operating Positioner**



**IMPORTANT**

When using two positioners working in split range and connected to the same analog output, impedances add up, resulting in 1220 ohms. (In the case of 2 positioners). Therefore, the analog output must withstand a voltage drop of 24.2 Volts.

# Section 10: Mechanical Dimensions

## 10.1 Rotary Positioner Dimensions

Figure 10-1 Rotary Positioner with Pressure Gauge

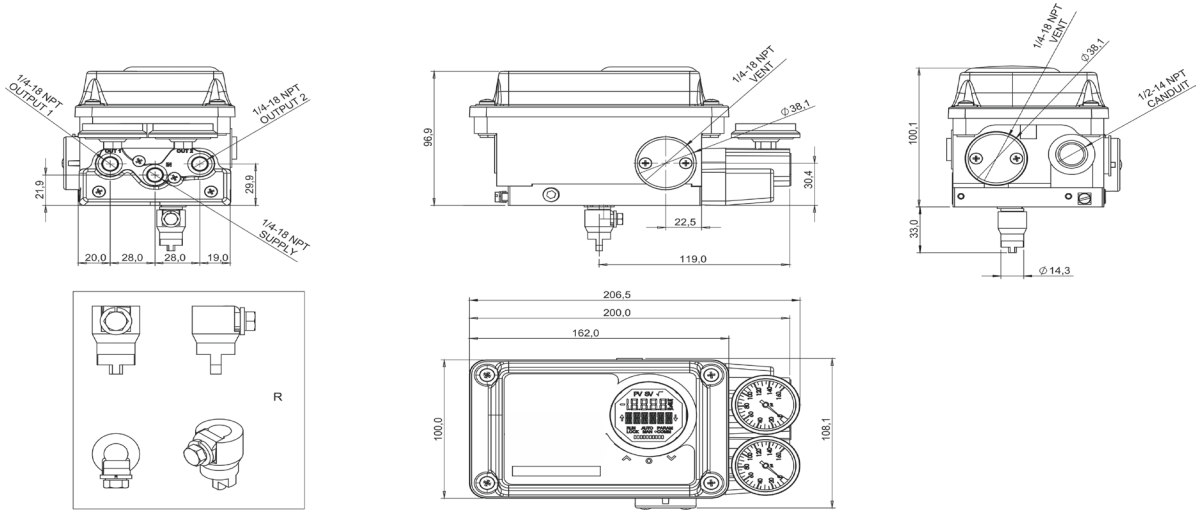

Mounting Torque:  
 Positioner in the mounting bracket (4xM6): 10 Nm  
 Mounting bracket on the rotary actuator (4XM5): 10 Nm

## 10.2 Linear Positioner Dimensions

Figure 10-2 Linear Positioner

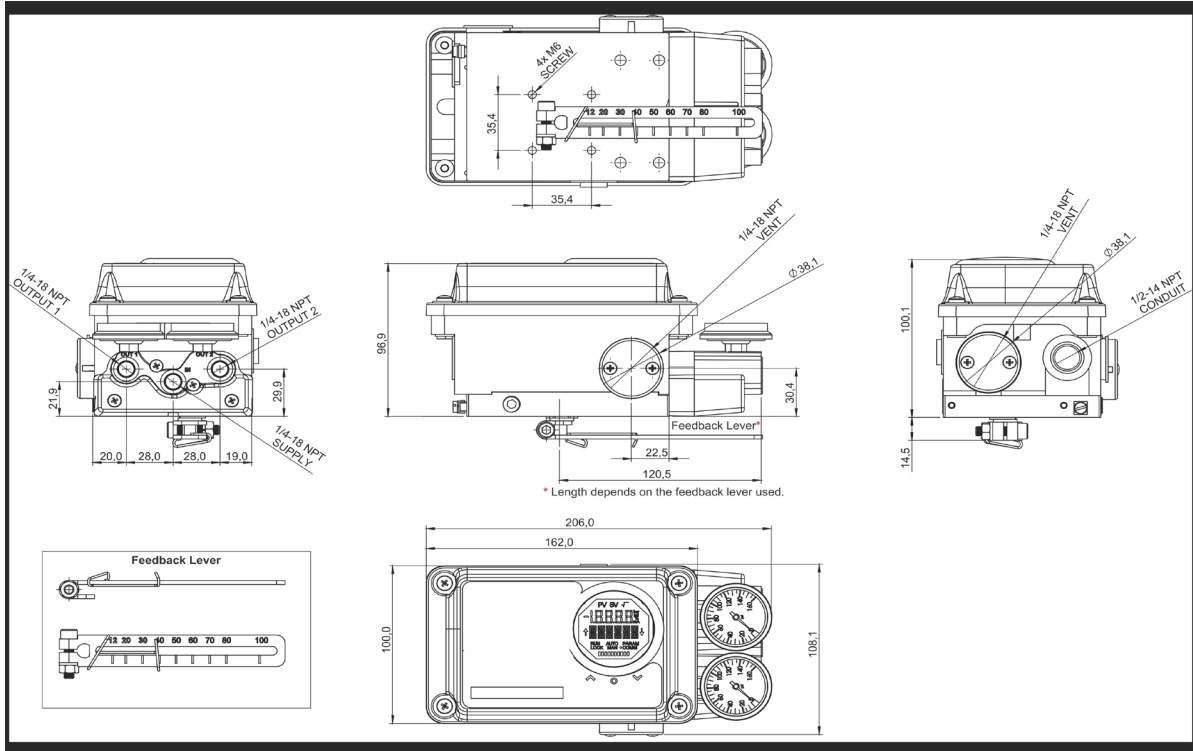

# Section 11: How To Specify

## PD200-HSNGXX0000-ES

PD200 - H (4-20mA with HART) - S (Mechanical Key + 4-20mA Position Transmitter), - N (One input conduit 1/2" NPT / Manifold 1/4" NPT standard), - G (Long manifold with two PSI manometers) - XX (RN [Rotating NAMUR adapter], K3 [Linear with 5 to 120mm feedback lever], and K4[Linear with 80 to 200mm feedback lever]), - 00 (Future placeholder for mounting bracket Options), - 00 (Future placeholder for additional options), - ES (Intrinsically Safe)

**Example:** PD200 - H S N G K3 00 00 - ES

<b>Model</b>	PD200 Smart Valve Positioner with enhanced controls
<b>Input &amp; Communication</b>	H 4-20mA with HART <sup>®</sup> 7
<b>Feedback Output</b>	S Isolated position feedback transmitter 4-20mA plus mechanical switches
<b>Electric and Pneumatic Connections</b>	N Single conduit entry 1/2" NPT / P pneumatic manifold with 1/4" NPT
<b>Pneumatic Manifold</b>	G ZAMAC Manifold with two pressure gauges
<b>Type of Actuator Adaptor</b>	RN Rotary NAMUR adaptor K3 Linear feedback lever 12-120mm K4 Linear feedback lever 80-200mm
<b>Actuator Mounting Brackets</b>	00 No mounting bracket included
<b>Other Options</b>	00 No other options
<b>Area Classification</b>	ES Intrinsically Safe
<b>Regional Certs</b>	Blank No regional certs

© 2013-2025 TopWorx, All rights reserved. TopWorx™, and GO™ Switch are all trademarks of TopWorx™. The Emerson logo is a trademark and a service mark of Emerson Electric. Co. © 2013-2025 Emerson Electric Company. All other marks are the property of their respective owners. Information herein – including product specifications – is subject to change without notice.

**Global Support Offices**

**North America**

3300 Fern Valley Road,  
Louisville, Kentucky 40213 USA  
1 502 969 8000  
[info.topworx@emerson.com](mailto:info.topworx@emerson.com)

**Asia-Pacific**

1 Pandan Crescent  
Singapore 128461  
65 6777 8211  
[info.topworx@emerson.com](mailto:info.topworx@emerson.com)

**Europe, Middle East, Africa**

Horsfield Way  
Bredbury Industrial Estate  
Stockport  
SK6 2SU UK  
United Kingdom  
44 0161 406 5155  
[info.topworx@emerson.com](mailto:info.topworx@emerson.com)